

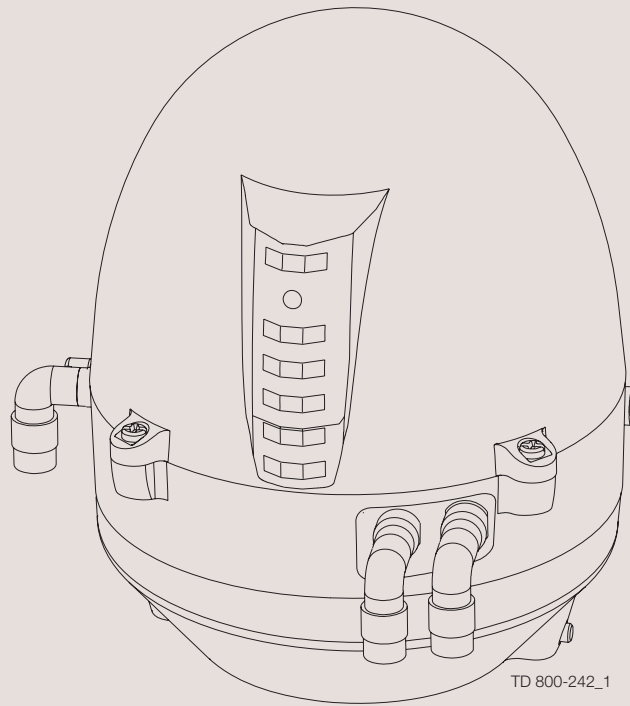

Instruction Manual

ThinkTop® Basic Digital 10 - 30 VDC PNP/NPN



Patented Sensor System
Registered Design
Registered Trademark

ESE00225-EN4 2011-01

Original manual

The information herein is correct at the time of issue but may be subject to change without prior notice

1. EC Declaration of Conformity	4
2. Safety	5
2.1. Important information	5
2.2. Warning signs	5
2.3. Safety precautions	6
3. General information	7
3.1. ThinkTop Basic in general	7
3.2. Recycling information	7
4. Technical specifications	8
4.1. ThinkTop Basic AS-Interface	8
5. Installation	11
5.1. Installation on air actuators	11
5.2. Installation on Series 700 Valves	14
5.3. Air connections	15
5.4. Electrical connection, internal	16
6. Setup diagram	17
6.1. ThinkTop Basic AS-Interface setup	17
7. Maintenance	18
7.1. Dismantling of ThinkTop	18
7.2. Assembly of ThinkTop	20
7.3. Dismantling and assembly of Series 700 Valves	22
8. Parts list and Service Kits	23
8.1. Drawings for ThinkTop Basic Digital	23
8.2. ThinkTop Basic Digital 10-30 VDC PNP/NPN	24
8.3. Drawings for ThinkTop Basic Digital for Series 700	27
8.4. ThinkTop Basic Digital for Series 700 Valves	28

1 EC Declaration of Conformity

The designating company

Alfa Laval

Company Name

Albuen 31, DK-6000 Kolding, Denmark

Address

+45 79 32 22 00

Phone No.

hereby declare that

Top Unit for Valve Control & Indication

Denomination

ThinkTop Basic

Type

Year

is in conformity with the following directives with amendments:

- Low Voltage Directive (LVD) 2006/95/EC
- EMC Directive 2004/108/EC
- ROHS Directive 2002/95/EC

Manager, Product Centres, Compact
Heat Exchangers & Fluid Handling

Title

Bjarne Søndergaard

Name

Alfa Laval Kolding
Company

Signature



Designation



*Unsafe practices and other important information are emphasized in this manual.
Warnings are emphasized by means of special signs. All warnings in the manual are summarized on this page.
Pay special attention to the instructions below so that severe personal injury or damage to the top unit are avoided.*

2.1 Important information

Always read the manual before using the top unit!

WARNING

Indicates that special procedures must be followed to avoid severe personal injury.

CAUTION

Indicates that special procedures must be followed to avoid damage to the ThinkTop Basic.

NOTE

Indicates important information to simplify or clarify procedures.

2.2 Warning signs

General warning:



Dangerous electrical voltage:



Caustic agents:



2 Safety

Unsafe practices and other important information are emphasized in this manual.

Warnings are emphasized by means of special signs. All warnings in the manual are summarized on this page.

Pay special attention to the instructions below so that severe personal injury or damage to the top unit are avoided.

2.3 Safety precautions

Installation:

Always read the technical data thoroughly (See chapter 6 Setup diagram)

Never install the ThinkTop Basic before valve or relay is in a safe position

If welding close to the ThinkTop Basic: **Always** earth close to the welding area

Disconnect the ThinkTop Basic



Always have the ThinkTop Basic electrically connected by authorized personnel



Maintenance:

Always read the technical data thoroughly (See chapter 6 Setup diagram)

Always fit the seals between valve and ThinkTop Basic correctly

Never install the ThinkTop Basic before valve or relay is in a safe position

Never service the ThinkTop Basic with valve/actuator under pressure

Never clean the ThinkTop Basic with high pressure cleaning equipment

Never touch the moving parts if the actuator is supplied with compressed air

Never use cleaning agents when cleaning the ThinkTop Basic. Check with cleaning agent supplier.



3.1 ThinkTop Basic in general

The ThinkTop Basic is designed to ensure valve control in conjunction with Alfa Laval sanitary valves and it is compatible with all major PLC systems (Programmable Logic Controllers maker with PNP/NPN interface).

The ThinkTop Basic can be equipped with 0-3 solenoid valves. The solenoids are electrically controlled via the Digital PLC and when activated the compressed air is activating the air actuator. All solenoid valves have build-in throttle function on both air inlet and outlet which means that it is possible to control the opening and closing time of the air actuators.

Visual LED lights are constantly indicating the status of the unit: Valve positions, solenoid activated, setup and local fault indication etc.

The ThinkTop Basic is characterized by a simple and modular design.

3.2 Recycling information

- **Unpacking**

- Packing material consists of wood, plastics, cardboard boxes and in some cases metal straps
- Wood and cardboard boxes can be reused, recycled or used for energy recovery
- Plastics should be recycled or burnt at a licensed waste incineration plant
- Metal straps should be sent for material recycling

- **Maintenance**

- During maintenance oil and wear parts in the machine are replaced
- All metal parts should be sent for material recycling
- Worn out or defective electronic parts should be sent to a licensed handler for material recycling
- Oil and all non metal wear parts must be taken care of in agreement with local regulations

- **Scrapping**

- At end of use, the equipment shall be recycled according to relevant, local regulations. Beside the equipment itself, any hazardous residues from the process liquid must be considered and dealt with in a proper manner. When in doubt, or in the absence of local regulations, please contact the local Alfa Laval sales company
-

4 Technical specifications

4.1 ThinkTop Basic AS-Interface

"No Touch" sensor system

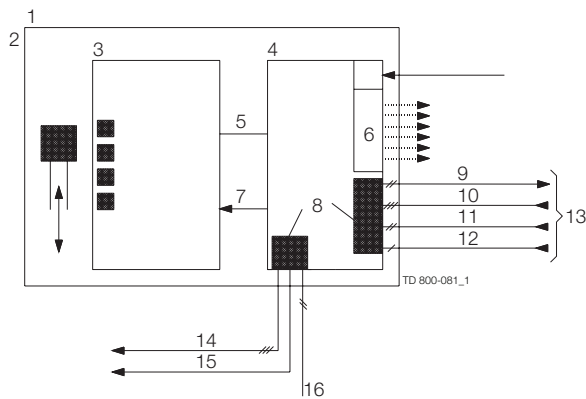

- | | |
|------------------------|------------------------------|
| 1. Sensor board | 9. Feedback signals (DC) |
| 2. PLC, DC feedback | 10. Solenoid signals (DC/AC) |
| 3. Sensor unit | 11. Supply voltage (DC) |
| 4. PLC interface board | 12. Solenoid common |
| 5. Serial link | 13. PLC Cable |
| 6. LEDs | 14. Solenoid signals (DC/AC) |
| 7. +5 V | 15. Solenoid common |
| 8. Terminals | 16. PNP/NPN jumper |

Type: Alfa Laval "No Touch" System. For wire connections: See 5.4 Electrical connection, internal".

Features

- Easy and simple set-up, using locally pushbuttons.
- No manual sensor adjustments at all.
- No sensor "movements" due to vibrations.
- Modular and hygienic design with exchangeabilities.
- Clear LED's for visual status indication.
- Setup parameters saved in case of power failure.

Sensor System

Unique "No Touch" sensor system without any mechanical sensor adjustments. A magnet (indication pin) is mounted on the valve stem and the magnetic field (axial) is detected by sensor chips inside the sensor unit. The measuring angle from each chip is used to locate the current position of the valve stem with an accuracy of ± 0.1 mm. Note that the distance to the indication pin can be $5 \text{ mm} \pm 3 \text{ mm}$.

Feedback signals

The sensor system can be used for 2 digital PNP/NPN feedback signals. Selection of PNP or NPN is done by a jumper.

Electrical connection

Direct main cable gland entry (hard wired) PG11 ($\phi 4 - \phi 10 \text{ mm}$).

Output signals from the sensor unit to the connected digital interface (PLC).

Nominal voltage: Same as connected to the ThinkTop Basic.

Load current: 50 mA typical, 100 mA max.

Voltage drop: Typical 3 V 50 mA.

4 Technical specifications

Technical specifications	
0 to 3 solenoid valves in each unit.	
Type	3/2 or 5/2 valve (only possible with one 5/2 valve)
Air supply	300-900 kPa (3-9 bar)
Filtered air, max. particles or dirt	5 μ 5-5 mg/m ³
Max. flow	180 l/min
Max. oil content	1 mg/m ³
Max. water content	0.88 g/m ³ -20 °C compressed air
Throughput	ø2.5 mm
Manual hold override.	Yes
External air tube connection	ø6 mm or 1/4" (specify when ordering)
Nominal voltage	24 VDC
Nominal power	1.0 W
Silencer/filter	Connection possible via ø6 mm or 1/4". (Filter recommended in tropical regions)
Materials	
Plastic parts	Nylon PA6
Steel parts	Stainless steel AISI 304
Air fitting	Special coated brass (FDA approved)
Seals	Nitrile (NBR)
Gore vent. membrane	PBT plastic

Micro environment demand specifications

Temperature		
Working:	-20°C to +85°C	IEC 68-2-1/2
Storage:	-40°C to +85°C	IEC 68-2-1/2
Temperature change:	-25°C to +70°C	IEC 68-2-14
Vibration		
	10-55 Hz, 0.7 mm	IEC 68-2-6
	55-500 Hz, 10g	
	3 x 30 min, 1 octave/min	
Drop test		
		IEC 68-2-32
Humidity		
Constant humidity:	+40°C, 21 days, 93% R.H.	IEC 60068-2-78
Cyclic humidity:	+25°C/+55°C	
	12 cycles	
(working)	93% R.H.	
Protection class		
	IP66 and IP67	IEC 60529
Input treshold		
Voltage/current:	Type 1 input requirements	EN 61131-2
Solenoid signals		
Isolation voltage	(1000 + 2 x 117) VAC rms/1 min	
EMC Directive		
	2004/108/EC	EN 61000-6-3, EN 61000-6-2
UL/CSA		
	10-30 VDC, Class 2 input, 45 mA max. output	UL 508-E203255

5.1 Installation on air actuators

Step 1



Always read the technical data thoroughly.



Always have the ThinkTop Basic electrically connected by authorized personnel.



Never install the ThinkTop Basic before valve or relay is in a safe position.

Step 2

1. Fit the air fittings on actuator if not mounted.
2. Fit the indication pin and tighten **carefully** with a spanner.

SRC only

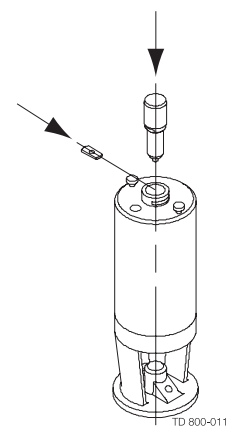

TD 800-011

Step 3

1. Place the ThinkTop Basic on top of the actuator.
2. Make sure X-ring is mounted.

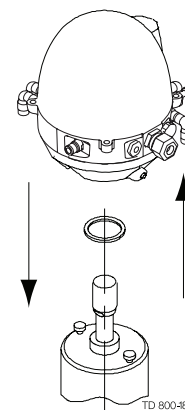

TD 800-485

5 Installation

Step 4

1. Ensure that the unit is correctly mounted by **pressing** down on top of the ThinkTop Basic.
2. Tighten the two Allen screws **carefully** (1.50 Nm).
3. Turn the actuator to have LEDs in a front view.

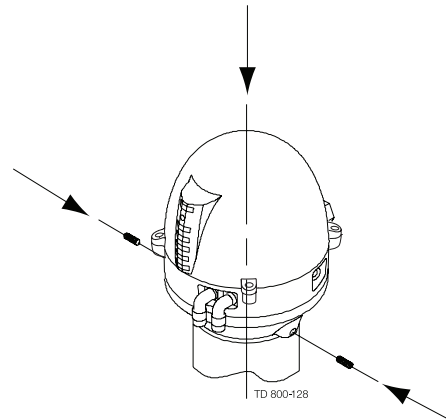

Step 5

Fit the $\varnothing 6$ mm (1/4") air tubes to ThinkTop Basic.
(see drawing "Air connections" page 15).

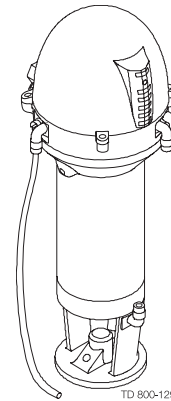

Step 6

Fit the air tubes to the actuator
(see drawing "Air connections" page 15).

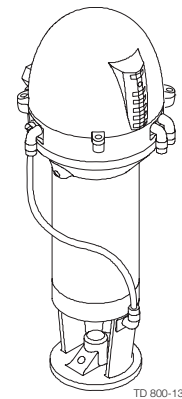

Step 7

Untighten the four screws and pull off cover of ThinkTop Basic.

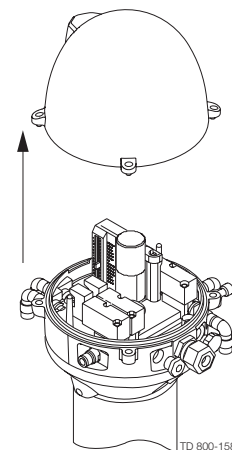

Step 8

1. Install cable (if not present) through the cable gland.
2. Connect the ThinkTop Basic electrically (see page 5.4 Electrical connection, internal).

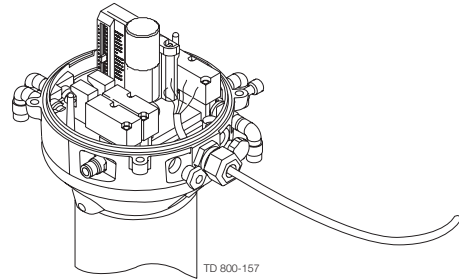

Step 9

Make sure the cable gland is completely tightened.

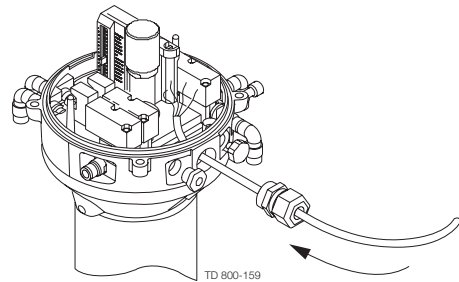

Step 10

Set up the ThinkTop Basic (see chapter 6 Setup diagram).

NOTE!

The unit can be set up by internal push buttons on sensor board.
To energize the valve, use manual hold override on the solenoids valve or be in radio contact with the control room.

5 Installation

5.2 Installation on Series 700 Valves

Step 1

1. Remove the cover by loosening the four cross recess screws.
2. Separate the adapter from the base by loosening the three recess screws on top of the base.

Installation on air actuators:

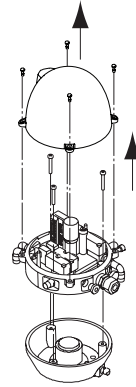

Step 2

1. Fit air fittings on actuator.
2. Position packing retainer in recess on actuator top.
3. Fit counter nut and indicator (magnet) on actuator rod. Engage approx. $\frac{1}{4}$ " thread. Tighten counter nut and indicator with two wrenches.

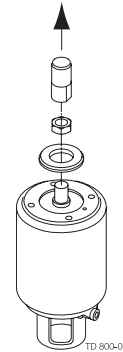

Step 3

1. Place the two O-rings in the grooves in the bottom of the adapter. Then place the adapter on the actuator top. The small O-ring must be positioned over the air hole on the actuator.
2. Fasten the adapter with the four $\frac{5}{16}$ " Allen screws.

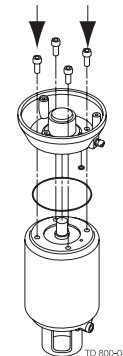

Step 4

Mount the base on the adapter in the position needed (can be rotated 120° in both directions). Note that one of the screw towers on the adapter has a guide recess (see * on drawing).

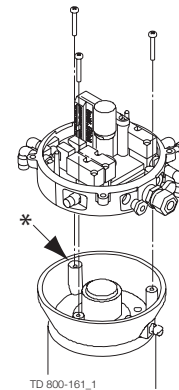

5.3 Air connections

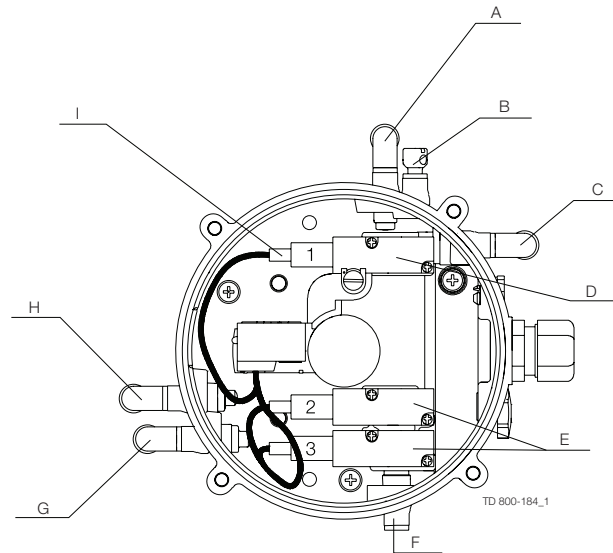

- A. Air out 1A
 - B. Air exhaust
 - C. Air out 1B (5/2 port solenoid valve only)
 - D. Solenoid 3/2 or 5/2
 - E. Solenoid valve (3/2) only
 - F. Air in
 - G. Air out 3
 - H. Air out 2
 - I. Manual hold override
-

5 Installation

5.4 Electrical connection, internal

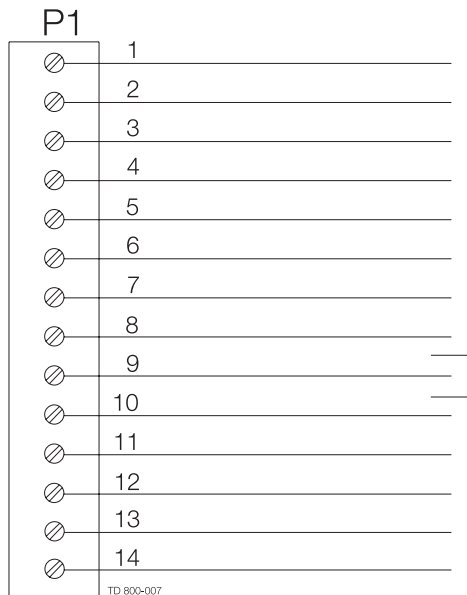

Electrical connections, internal

1. De-energized (PLC input)
2. Energized (PLC input)
3. Activation of solenoid # 1 (PLC output)
4. Activation of solenoid # 2 (PLC output)
5. Activation of solenoid # 3 (PLC output)
6. Supply voltage sensor (+) 10-30 VDC
7. Supply voltage sensor (0) 0 V
8. Common supply solenoids
9. PNP/NPN jumper*)
10. PNP/NPN jumper*)
11. Solenoid common, internal connection
12. Solenoid # 1, internal connection
13. Solenoid # 2, internal connection
14. Solenoid # 3, internal connection

*) Jumper present = PNP.

If changing the function a power recycle is necessary.
The selection NPN/PLC is done by the jumper.

Note! Remember to isolate wires that are not in use.

6.1 ThinkTop Basic AS-Interface setup

ThinkTop Basic Digital and AS-Interface

A printable "one page" version of ThinkTop Basic setup diagram is available on the Alfa Laval website and can easily be found by typing the document name "ThinkTop Basic setup diagram" in the search field.

Time-out: A 60 second time-out is started as soon as any button(s) are released. If no button is pressed during the time-out period, go to normal condition (cancel & exit).

Red LED: Active during set-up

- Flashing in step 1
- Steady in all other steps

or during operations, error condition:

- Steady showing hardware fault, indication pin out of range
- Flashing showing software fault

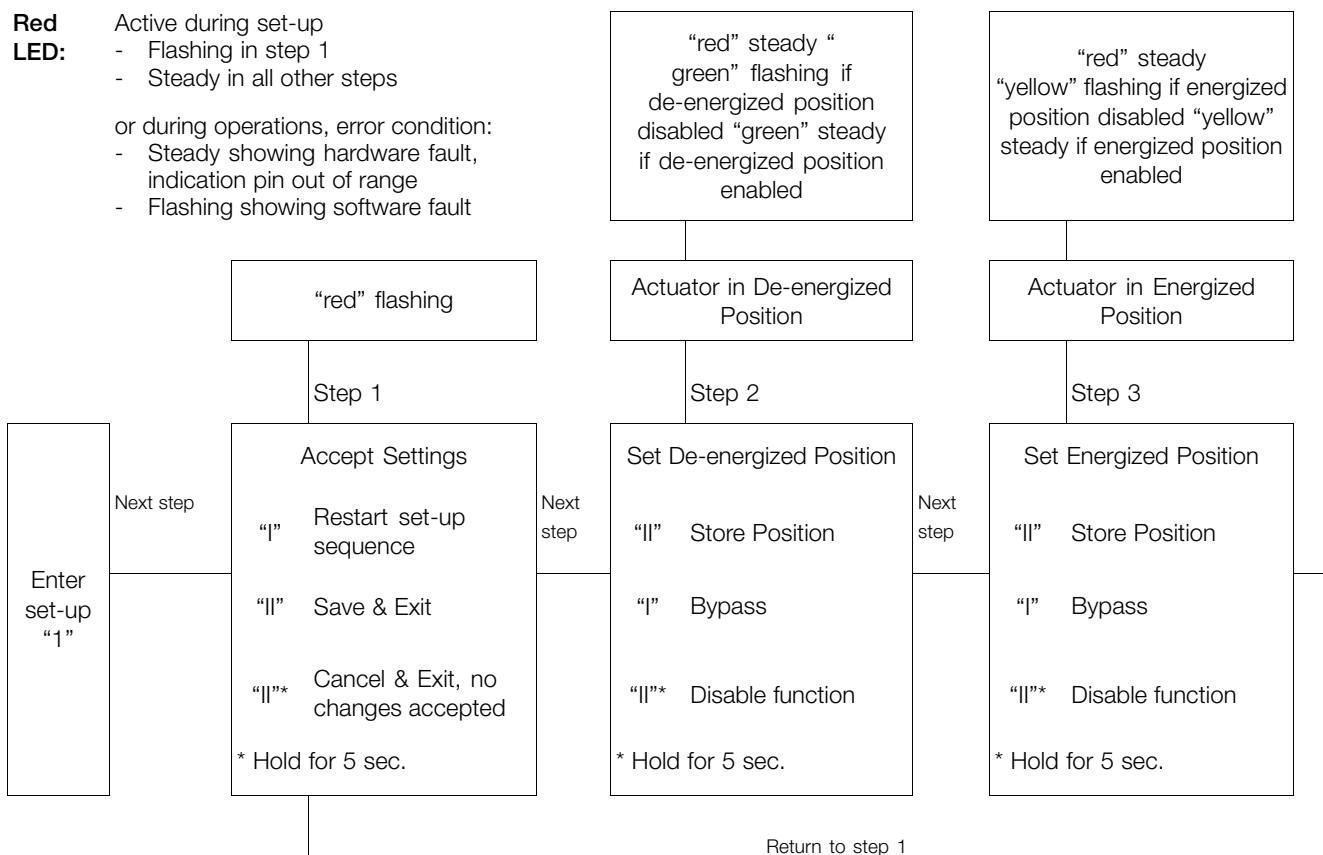

Quick set-up:

Push: "1", enter setup and wait until red LED flashes.
 Push: "1", restart set-up.

Actuator in De-energized position

Push: "11", store position

Actuator in energized position

Push: "11", store position
 Push: "11", when red LED is flashing (save & exit)
 Set-up done.

7 Maintenance

Study the instructions carefully.

Handle scrap correctly.

Always keep spare X-rings in stock.

7.1 Dismantling of ThinkTop

Step 1

1. Remove the ThinkTop Basic from the actuator.
2. Pull out X-ring (19) and replace it.

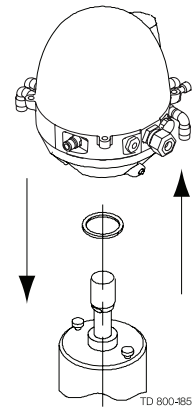

Step 2

1. Untighten the four screws.
2. Pull off cover of ThinkTop Basic.
3. Remove the grey X-ring (9).

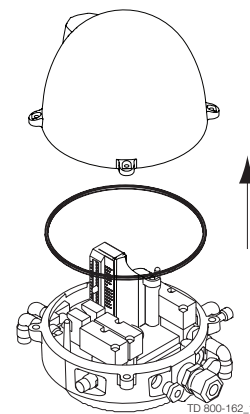

Step 3

1. Untighten screws.
2. Remove solenoid valves (up to three) and replace them with new ones.

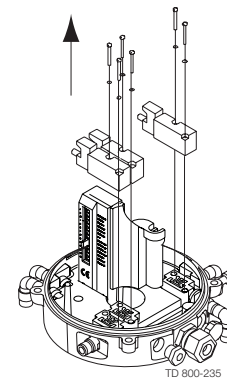

Step 4

1. To dismantle the adapter (the lower part of the ThinkTop Basic) from base (the middle part), unscrew the three screws.
2. Turn the lower part a little clockwise and pull.
3. Replace adapter if necessary.
4. Remove the black X-ring.

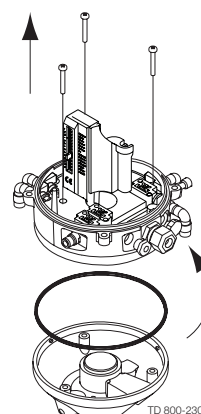

Note: Turn banjo connection!

*Study the instructions carefully.
Handle scrap correctly.
Always keep spare X-rings in stock.*

Step 5

To remove the sensor unit untighten screw and pull out the sensor unit.

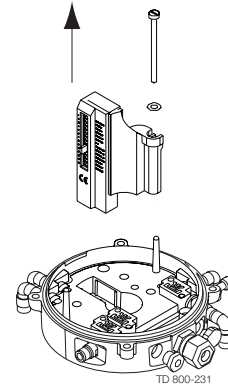

7 Maintenance

Study the instructions carefully.

Handle scrap correctly.

Always keep spare X-rings in stock.

7.2 Assembly of ThinkTop

Step 1

Place sensor unit in base and tighten screw (torque: 1 Nm).

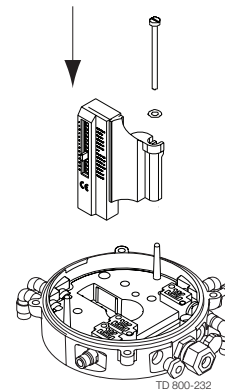

Step 2

1. Replace the black X-ring.
2. Assemble base with adapter by turning adapter slightly anticlockwise and tighten the four screws (1.9 Nm).

CAUTION!

Do NOT twist the X-ring in the groove!

The X-ring is not square; The highest (h) part must be placed as fig.

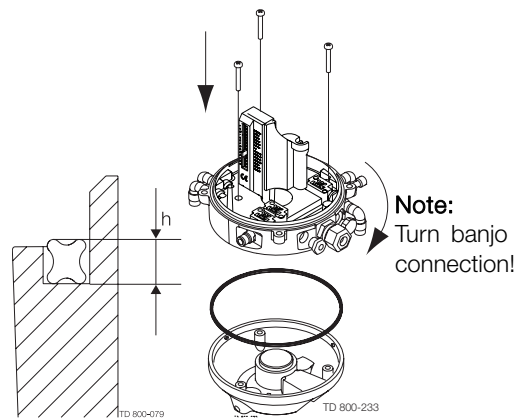

Step 3

1. Replace solenoid valves (up to three) with new ones.
2. Tighten screws (0.2 Nm).

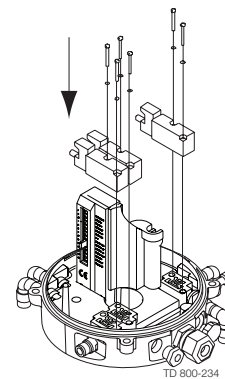

Step 4

1. Replace the grey X-ring.
2. Replace cover of ThinkTop Basic and tighten the four screws (0.6 Nm).

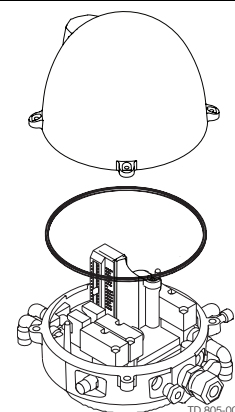

*Study the instructions carefully.
Handle scrap correctly.
Always keep spare X-rings in stock.*

Step 5

- 1. Replace the black X-ring.
- 2. Mount ThinkTop Basic on actuator.

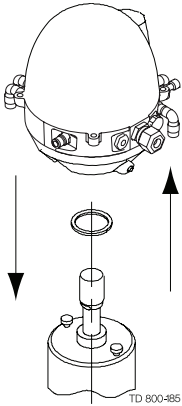

7 Maintenance

Study the instructions carefully.

Handle scrap correctly.

Always keep spare X-rings in stock.

7.3 Dismantling and assembly of Series 700 Valves

Step 1

1. Remove the cover by loosening the four cross recess screws.
2. Separate the adapter from the base by loosening the three recess screws on top of the base.

Installation on air actuators:

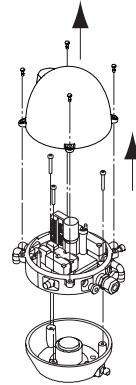

TD 800-160

Step 2

1. Fit air fittings on actuator.
2. Position packing retainer in recess on actuator top.
3. Fit counter nut and indicator (magnet) on actuator rod. Engage approx. 1/4" thread. Tighten counter nut and indicator with two wrenches.

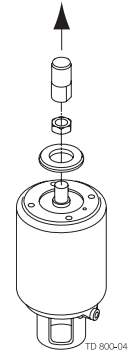

TD 800-048

Step 3

1. Place the two O-rings in the grooves in the bottom of the adapter. Then place the adapter on the actuator top. The small O-ring must be positioned over the air hole on the actuator.
2. Fasten the adapter with the four 5/16" Allen screws.

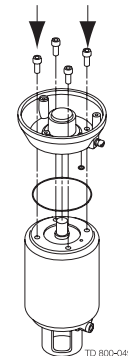

TD 800-049

Step 4

- Remove x-rings (9) (grey) and (16) (black).
- Replace with new ones.
- Mount the base on the adapter in the position needed (can be rotated 120° in both directions). Note that one of the screw towers on the adapter has a guide recess (see * on drawing).

CAUTION!

Do **NOT** twist the X-ring (16) in the groove! The X-ring is not square; The highest (h) part must be placed as fig.

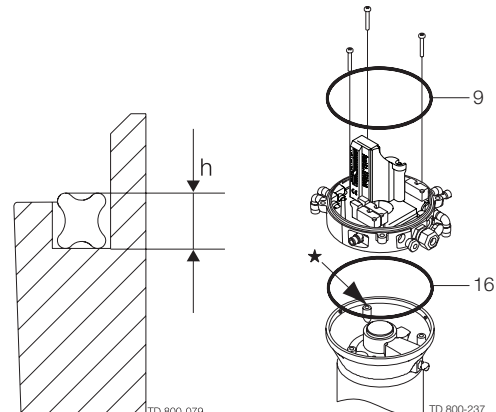

TD 800-079

TD 800-237

8 Parts list and Service Kits

The drawings show ThinkTop Basic Digital 10 - 30 VDC PNP/NPN.
 The items refer to the parts lists in the following sections

8.1 Drawings for ThinkTop Basic Digital

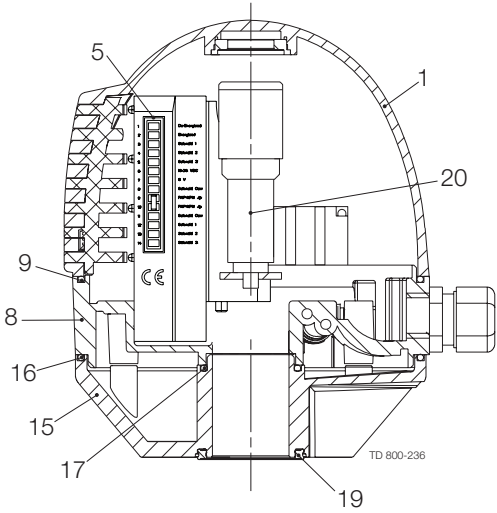
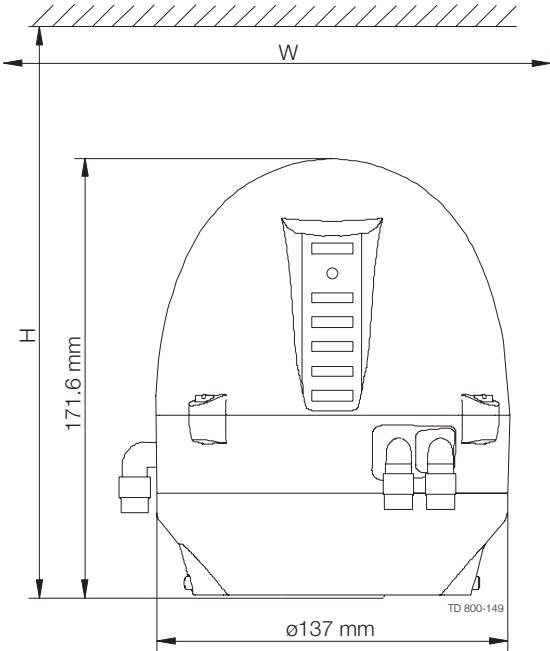

Note! This is the basic design.

Valve Type	W	H
Unique SSV NC	225	250
SMP-SC/-BC/-TO	225	250
Unique Mixproof	225	250
MH	225	250
SBV	225	250
Unique SSV NO	225	320
LKLA-T	225	300

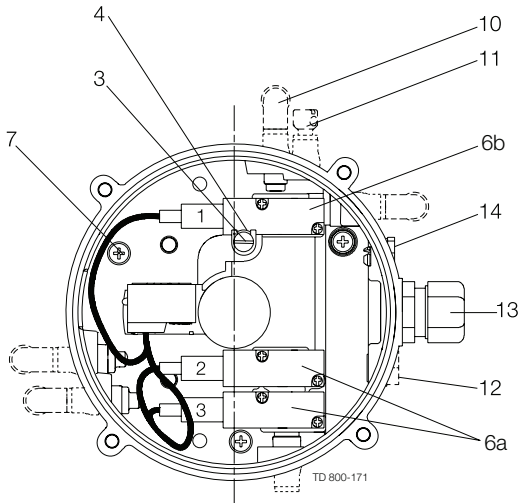

8 Parts list and Service Kits

The drawings show ThinkTop Basic Digital 10 - 30 VDC PNP/NPN.
The items refer to the parts lists in the following sections

8.2 ThinkTop Basic Digital 10-30 VDC PNP/NPN

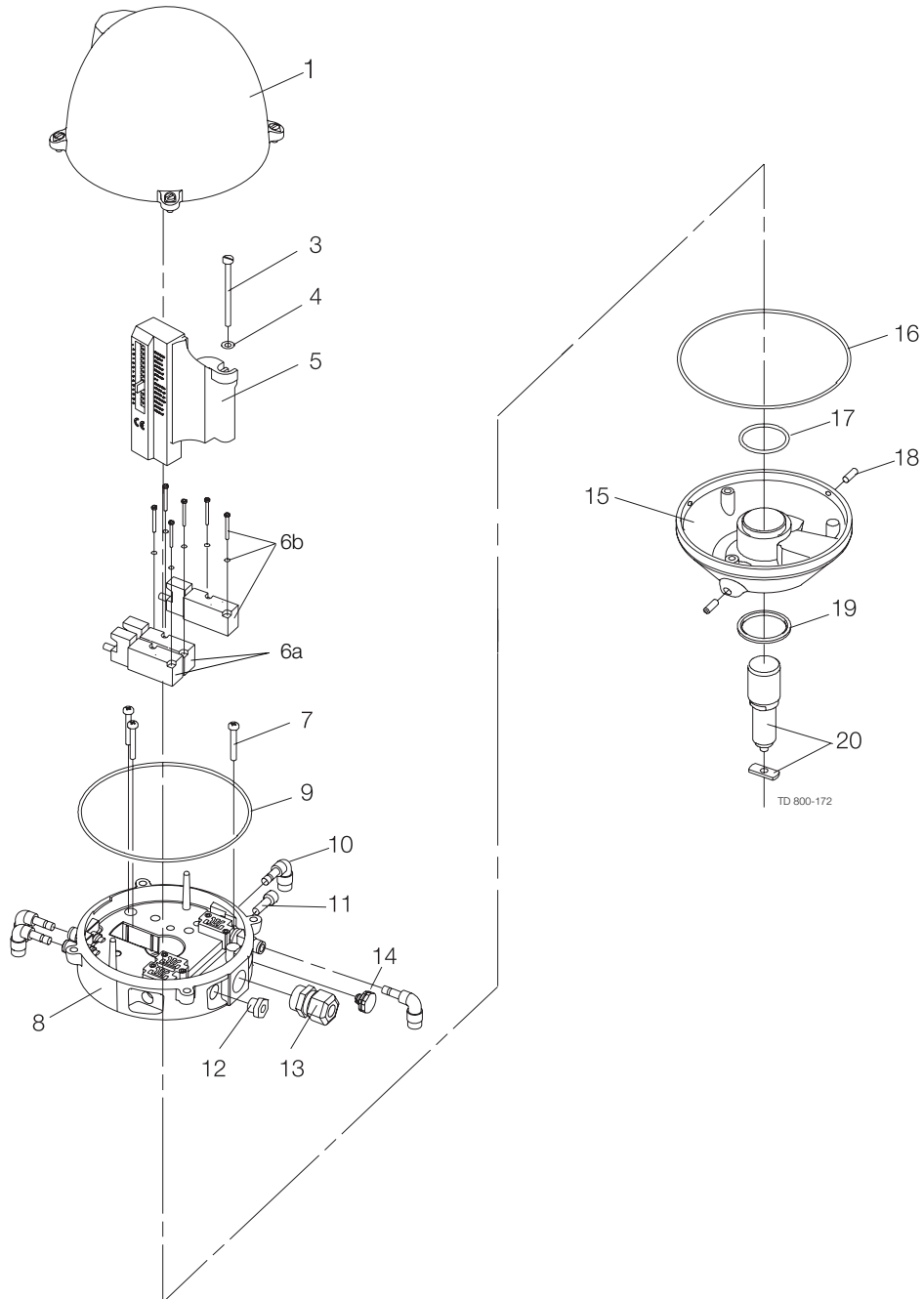

The drawings show ThinkTop Basic Digital 10 - 30 VDC PNP/NPN.
The items refer to the parts lists in the following sections

Parts list

Pos.	Qty	Denomination
1	1	Shell complete
3	1	Screw
4	1	Washer
5	1	Sensor board Digital 10-30 VDC PNP/NPN
6a	1-3	Solenoid valve
7	3	PT screw
8	1	Base
9	1	Special X-ring, grey
10	1	Air fitting
11	1	Blow-off valve
12	1	Thread plug, PG7 ø3-ø6.5 mm
13	1	Cable gland, PG11 ø4-ø10 mm
14	1	Gore vent High airflow
15	1	Adapter complete (Pos. 17,18,19 included)
16	1	Special X-ring, black
17	1	O-ring
18	2	Allen screw
19	1	Special X-ring
20	1	Indication pin

Service kits

Sensor unit Digital 8-30 VDC PNP/NPN	9613-4192-01
Solenoid valve 3/2, 24 VDC	9611-99-4635
Solenoid valve 5/2, 24 VDC	9611-99-3327
Indication pin	9612-5623-01
Special indication pin, SRC-LS	9612-6370-01
Special indication pin, Unique SSV-LS	9613-1581-01
Special indication pin, Unique SSV High Pressure	9613-1581-01
Air fitting, Ø6 mm	9611-99-3405
Air fitting, 1/4"	9611-99-3433
Gore vent	9611-99-4722
X-ring, pos. 9	9613-4564-01
X-ring, pos. 16	9612-9994-01
X-ring, pos. 19	9612-5696-01

8 Parts list and Service Kits

The drawings show ThinkTop Basic Digital 10 - 30 VDC PNP/NPN Series 700 valves.
The items refer to the parts lists in the following sections

8.3 Drawings for ThinkTop Basic Digital for Series 700

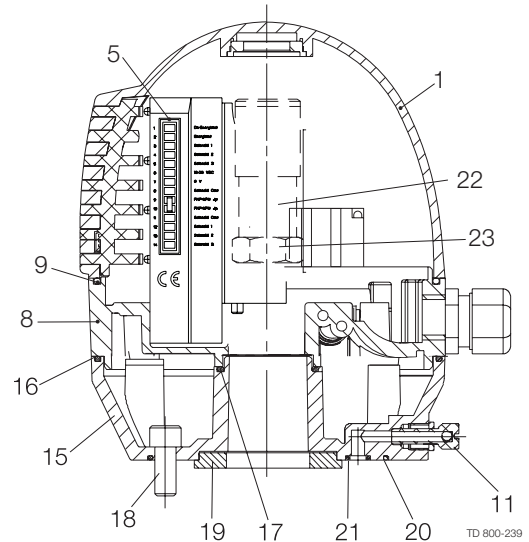
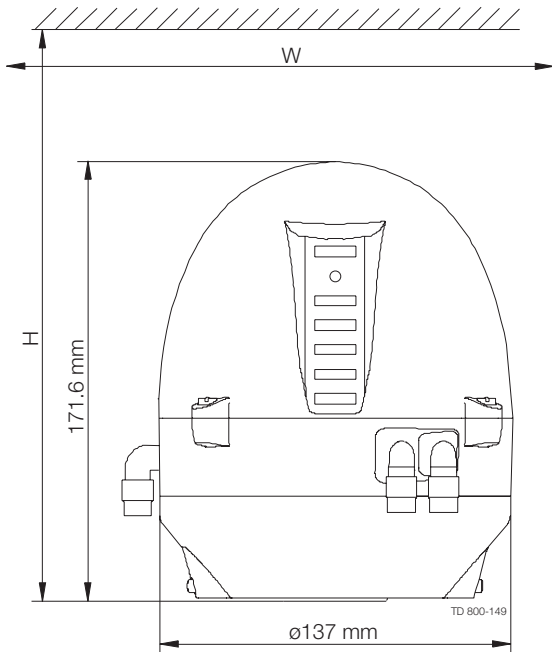

Note! This is the basic design.

Valve Type	W	H
Unique SSV NC	225	250
SMP-SC/-BC/-TO	225	250
Unique Mixproof	225	250
MH	225	250
SBV	225	250
Unique SSV NO	225	320
LKLA-T	225	300

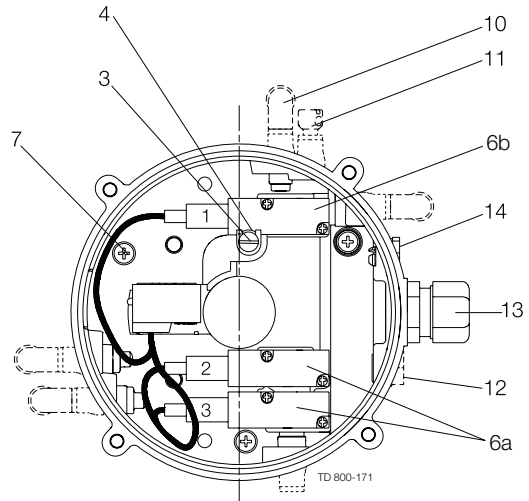

8 Parts list and Service Kits

The drawings show ThinkTop Basic Digital 10 - 30 VDC PNP/NPN Series 700 valves.
The items refer to the parts lists in the following sections

8.4 ThinkTop Basic Digital for Series 700 Valves

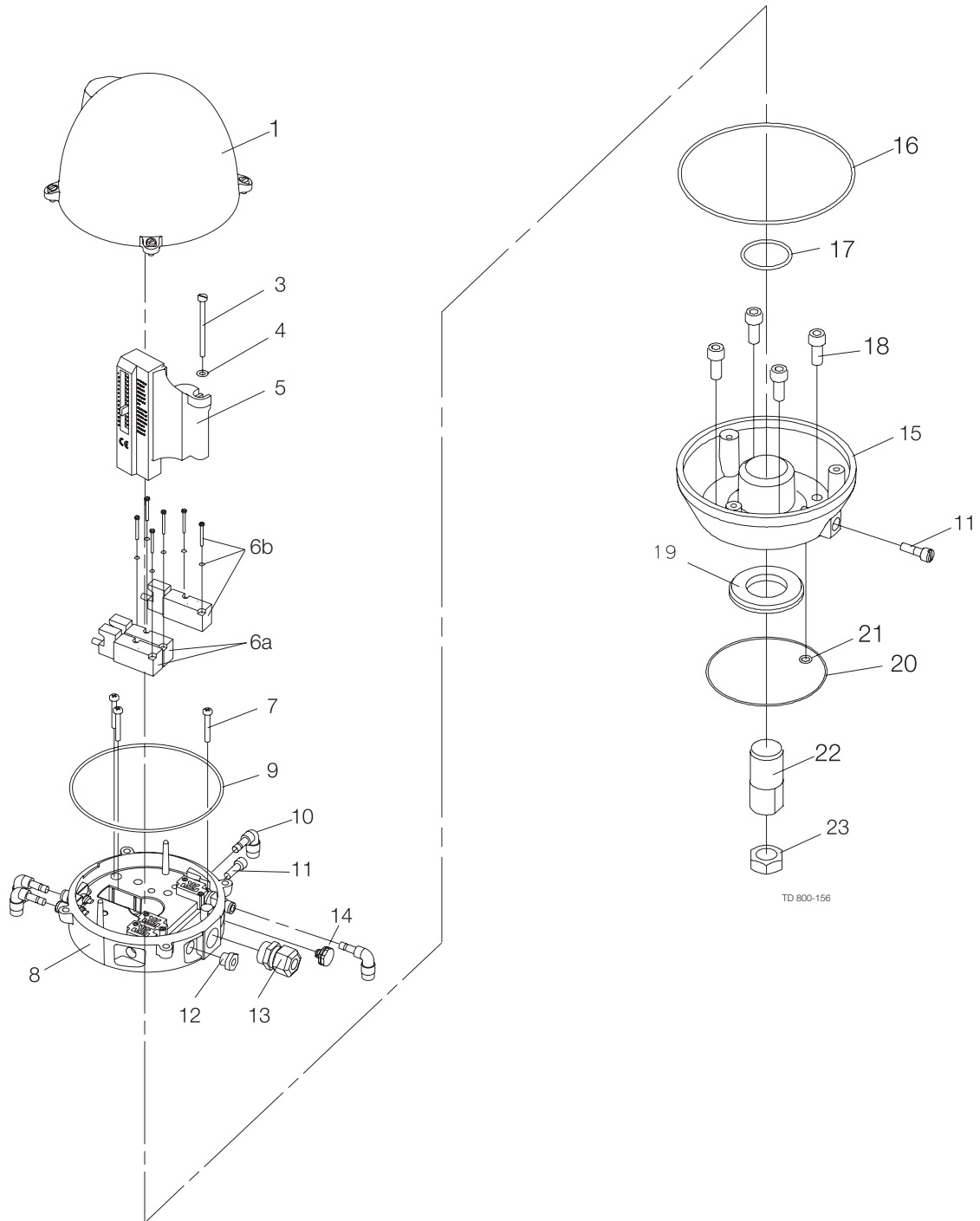

8 Parts list and Service Kits

The drawings show ThinkTop Basic Digital 10 - 30 VDC PNP/NPN Series 700 valves.
The items refer to the parts lists in the following sections

Parts list

Pos.	Qty	Denomination
1	1	Shell complete
3	1	Screw
4	1	Washer
5	1	Sensor board 10-30 VDC PNP/NPN
6a	1-3	Solenoid valve
7	3	PT screw
8	1	Base
9	1	Special X-ring, grey
10	1	Air fitting
11	2	Blow-off valve
12	1	Thread plug, PG7 ø3-ø6.5 mm
13	1	Cable gland, PG11 ø4-ø10 mm
14	1	Gore vent High airflow
15	1	Adapter complete
16	1	Special X-ring, black
17	1	O-ring
18	4	Screw
19	1	Retainer
20	1	O-ring
21	1	O-ring
22	1	Indicator pin
23	1	Nut

Service kits

Sensor unit Digital 8-30 VDC PNP/NPN	9613-4192-01
Solenoid valve 3/2, 24 VDC	9611-99-4635
Solenoid valve 5/2, 24 VDC	9611-99-3327
Indication pin	9612-5623-01
Special indication pin, SRC-LS	9612-6370-01
Special indication pin, Unique SSV-LS	9613-1581-01
Air fitting, 1/4"	9611-99-3433
Gore vent	9611-99-4722
X-ring, pos. 9	9613-4564-01
X-ring, pos. 16	9612-9994-01

TD 900-368/2

How to contact Alfa Laval

Contact details for all countries are continually updated on our website.

Please visit www.alfalaval.com to access the information direct.

© Alfa Laval Corporate AB

This document and its contents is owned by Alfa Laval Corporate AB and protected by laws governing intellectual property and thereto related rights. It is the responsibility of the user of this document to comply with all applicable intellectual property laws. Without limiting any rights related to this document, no part of this document may be copied, reproduced or transmitted in any form or by any means (electronic, mechanical, photocopying, recording, or otherwise), or for any purpose, without the expressed permission of Alfa Laval Corporate AB. Alfa Laval Corporate AB will enforce its rights related to this document to the fullest extent of the law, including the seeking of criminal prosecution.