

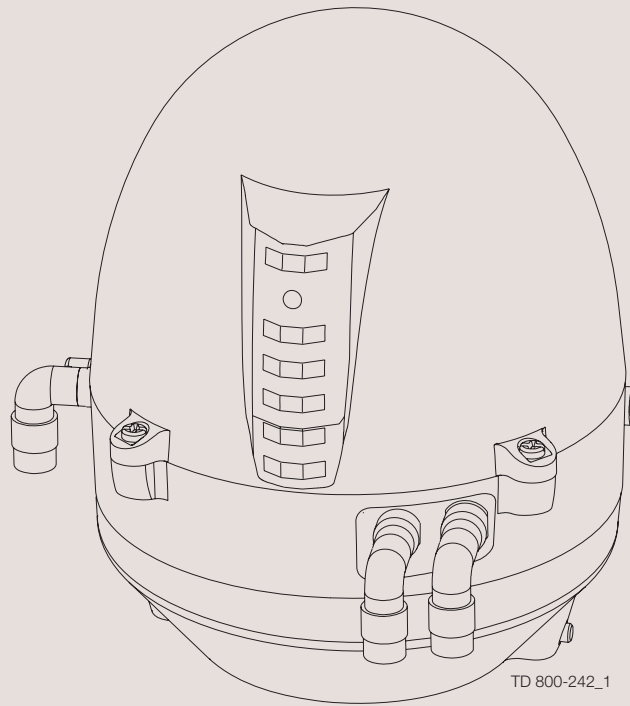

Instruction Manual

ThinkTop® Digital 8 - 30 VDC PNP/NPN



Patented Sensor System
Registered Design
Registered Trademark

ESE00353-EN11 2011-01

Original manual

The information herein is correct at the time of issue but may be subject to change without prior notice

1. EC Declaration of Conformity	4
2. Safety	5
2.1. Important information	5
2.2. Warning signs	5
2.3. Safety precautions	6
3. General information	7
3.1. Digital in general	7
4. Technical specifications	8
4.1. ThinkTop, PLC 8-30 VDC interface	8
5. Installation	12
5.1. Installation on air actuators	12
5.2. Installation on Series 700 valves	15
5.3. Air connections	16
5.4. Electrical connection, internal	17
5.5. Example of connecting power supplies	18
6. Setup diagram	19
6.1. ThinkTop setup utilising IR keypad	19
6.2. ThinkTop setup utilising local 'I' and 'II' keys	21
6.3. ThinkTop quick setup guide	23
7. Fault finding	26
7.1. Fault finding and LEDs	26
8. Maintenance	28
8.1. Dismantling of ThinkTop	28
8.2. Assembly of ThinkTop	30
8.3. Dismantling and assembly of Series 700 valves	32
9. Parts list and Service Kits	33
9.1. Drawings for ThinkTop Digital VDC	33
9.2. ThinkTop Digital VDC	34
9.3. Drawings for ThinkTop VDC for Series 700	37
9.4. ThinkTop VDC for Series 700	38

1 EC Declaration of Conformity

The designating company

Alfa Laval

Company Name

Albuen 31, DK-6000 Kolding, Denmark

Address

+45 79 32 22 00

Phone No.

hereby declare that

Top Unit for Valve Control & Indication

Denomination

ThinkTop Digital VDC

Type

Year

is in conformity with the following directives with amendments:

- Low Voltage Directive (LVD) 2006/95/EF
- EMC Directive 2004/108/EF
- ROHS Directive 2002/95/EC

Manager, Product Centres, Compact
Heat Exchangers & Fluid Handling

Title

Bjarne Søndergaard

Name

Alfa Laval Kolding
Company

Signature



Designation



*Unsafe practices and other important information are emphasized in this manual.
Warnings are emphasized by means of special signs. All warnings in the manual are summarized on this page.
Pay special attention to the instructions below so that severe personal injury or damage to the top unit are avoided.*

2.1 Important information

Always read the manual before using the top unit!

WARNING

Indicates that special procedures must be followed to avoid severe personal injury.

CAUTION

Indicates that special procedures must be followed to avoid damage to the ThinkTop.

NOTE

Indicates important information to simplify or clarify procedures.

2.2 Warning signs

General warning:



Dangerous electrical voltage:



Caustic agents:



2 Safety

Unsafe practices and other important information are emphasized in this manual.

Warnings are emphasized by means of special signs. All warnings in the manual are summarized on this page.

Pay special attention to the instructions below so that severe personal injury or damage to the top unit are avoided.

2.3 Safety precautions

Installation

Always read the technical data thoroughly.



Never install the ThinkTop before valve or relay is in a safe position.



If welding close to the ThinkTop: **Always** earth close to the welding area.



Disconnect the ThinkTop.



Always have the ThinkTop electrically connected by authorized personnel.



Maintenance

Always read the technical data thoroughly.



Always fit the seals between valve and ThinkTop correctly.



Never service the ThinkTop before valve or relay is in a safe position.



Never service the ThinkTop with valve/actuator under pressure.



Never clean the ThinkTop with high pressure cleaning equipment.



Never use cleaning agents when cleaning the ThinkTop. Check with cleaning agent supplier.



3.1 Digital in general

The ThinkTop is designed to ensure optimum valve control in conjunction with Alfa Laval valves and it is compatible with most PLC systems (Programmable Logic Controllers maker with PNP/NPN interface).

The ThinkTop can be equipped with 0-3 solenoid valves. The solenoids are electrically controlled by the Digital PLC and when activated the compressed air is activating the air actuator. All solenoids have built-in throttle function on both air inlet and outlet which means that it is possible to control the opening and closing time of the air actuator. The solenoids are also equipped with a manual hold override.

Visual LED lights are constantly indicating the status of the unit: Valve positions, solenoid energized, setup and local fault indication etc.

The ThinkTop is characterized by a simple and modular design. It is exchangeable and is prepared for upgrading.

4 Technical specifications

4.1 ThinkTop, PLC 8-30 VDC interface

“No Touch” sensor system

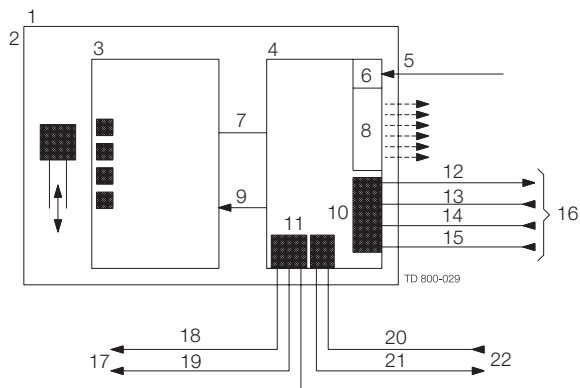

- | | |
|------------------------|------------------------------|
| 1. Sensor unit | 12. Feedback signals |
| 2. PLC, feedback | 13. Solenoid signals |
| 3. Sensor board | 14. Supply voltage |
| 4. PLC interface board | 15. Solenoid common |
| 5. IR Remote control | 16. PLC Cable |
| 6. IR Rx | 17. Internal connections |
| 7. Serial link | 18. Solenoid signals |
| 8. LEDs | 19. Solenoid common |
| 9. +5 V | 20. External seat-lift (PNP) |
| 10. Terminals | 21. Supply sensors |
| 11. Terminals | 22. External connections |

Type: Alfa Laval “No Touch” System. For wire connections: See 5.4 Electrical connection, internal.

Features

- Tolerance programmes.
- Self adjustment programme (SRC/ARC valves only).
- Built-in maintenance monitor.
- Setup by internal push buttons or remote control (IR Keypad).
- Setup and local fault supervision.
- Setup saved at power shutdown.
- Visual LED Indicator lights.

Sensor System

Unique “No Touch” sensor system without any mechanical sensor adjustments. A magnet (indication pin) is mounted on the valve stem and the magnetic field (axial) is detected by sensor chips inside the sensor board. The measuring angle from each chip is used to locate the current position of the valve stem with an accuracy of ± 0.1 mm. Note that the distance to the indication pin can be $5 \text{ mm} \pm 3 \text{ mm}$.

Feedback signals

The sensor system can be used for 4 feedback signals + 1 status signal = 5 digital PNP/NPN feedback signals. Selection of PNP or NPN is done by a jumper. Two of the feedback signals can be external sensors if necessary.

The status signal is used for detection of the following conditions:

- A set-up is in progress.
- Internal error.
- Maintenance is required (based on time and/or the self adjustment programme).

Tolerance programme

Individual programme according to valve types.

- | | |
|---------|--|
| Type 0: | Bypass valve type / keep present valve type. |
| Type 1: | SRC/ARC and Series 700 valves, only when self adjustment is enabled - Not recommended. |
| Type 2: | LKB (LKLA-T). |
| Type 3: | Unique Mixproof, SMP-SC Spillage-Free, and SRC-PV. |
| Type 4: | SMP-SC, SMP-TO, SMP-BC, SMP-BCA, SBV, SRC, ARC, Unique SSV, Unique SSV Aseptic, Unique-TO and Series 700 valves. |
| Type 5: | All Parameters Set To Default (also valid for MH valve and SMP-EC (seat-lift indication not possible for SMP-EC)). |

Preset and reset values: Tolerance programme No./Type 5 (± 5 mm) and all functions are disabled.

Note! Important to select the right tolerance programme in order to ensure optimum controlled closeness of valves.

Self Adjustment (SRC/ARC valves only)

The self adjustment feature is an exceptional aspect of the ThinkTop design. A programme can be activated to allow an adjustment of the tolerance band if the seals in the valve are being compressed or are worn. When the tolerance band of the unit has been adjusted 0.3 mm, an alert warning will appear in the form of a status signal and a flashing maintenance LED. After 0.5 mm adjustment an alarm warning appears: Loss of feedback signal, status signal and steady maintenance light indicating a replacement of the seal.

Built-in Maintenance Monitor

The unit can be preset to indicate when the time for maintenance of the valve has been reached. A status signal and flashing maintenance LED can be programmed to return after 3, 6, 9 or 12 months or more.

Technical specifications

Sensor system

Sensor accuracy: ± 0.1 mm.
Distance to indication pin: 5 ± 3 mm.
Stroke length: 0.1 - 80 mm.

Electrical connection:

Direct main cable gland entry (hard wired) PG11 ($\varnothing 4 - \varnothing 10$ mm).

Direct external/sensor cable gland entry PG7 ($\varnothing 3 - \varnothing 6.5$ mm) option, external sensor.

Terminals

The terminal row of the sensor unit is equipped with screw terminals for both internal as well as external cables and wires. The terminals are suitable for wires up to 0.75 mm^2 (AWG 19).

Power Supply, must meet the requirements of EN 61131-2

The ThinkTop is designed to be a part of the PLC's Input/Output (I/O) system. It should be supplied from the same protected power supply as the other I/O devices. The I/O power supply should not be used for other kinds of loads.

The unit is reverse polarity and short circuit protected.

Supply voltage: 8 - 30 VDC.
Supply voltage nominal: 24 VDC (+20%, -15%) - pr. EN 61131-2.
Max ripple: 5% of nominal supply voltage.
Supply voltage absolute max.: 30 VDC.
Supply voltage absolute min.: 8 VDC.
Supply current*): Max. 45 mA (for sensor unit alone)
(excluding current to the solenoids, external sensor and the PLC input current).

*) The initial current during power-on is higher. The actual shape of the current pulse depends on the power supply used. Typical values are 150 mA RMS during 13 ms (regulated PS) to 360 mA RMS during 8 ms (unregulated PS).

The fulfilling of the UL requirements in UL508 requires that the unit is supplied by an isolating source complying with the requirements for class 2 power units (UL1310) or class 2 and 3 transformers (UL1585).

Feedback signals

Output signals from the sensor unit to the connected PLC.

Nominal voltage: Must match the selected type of ThinkTop.
Load current: Typically 50 mA, max. 100 mA .
Voltage drop: Typically 3 V at 50 mA.

4 Technical specifications

External sensors

The external sensors are used for seat-lift supervision when seat-lift can not be internally detected. The sensors get their supply voltage from the terminal row. The output signals from the sensors are connected to two inputs on the terminal row on the internal sensor unit. If the actual setup is set for internal seat-lift, the corresponding external signal is not used, otherwise the external signal logically controls the corresponding feedback to the PLC (Programmable Logic Controller).

Note! If using external sensor, the sensor must be active/activated when performing a setup routine of the control head.

Supply voltage: Must match the selected type of ThinkTop.
 Supply current: Max. 15 mA per sensor.
 Type of sensor: DC, Only 3-wire sensor PNP.
 Sensor cable length: Max. 3 m.

Polarity

PNP (sourcing) or NPN (sinking) function is selected with a jumper in term. 12 and 13. Jumper present = PNP. If changing to NPN remove the jumper and make a power recycle. A power recycle is always required when changing this function.

ThinkTop Visual Indications

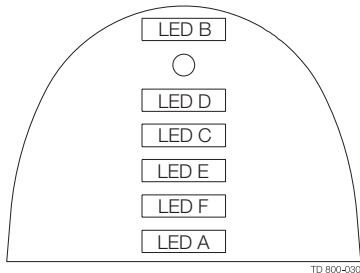

LED Indications

LED B	"Open valve" (Yellow)
O	IR-Receiver
LED D	"Setup/Internal fault" (Red)
LED C	"Seat-lift 1/2" (Yellow)
LED E	"Solenoid valves" (Green)
LED F	"Maintenance" (Orange)
LED A	"Closed valve" (Yellow)

Feedback signals

Signal:	"Closed Valve"	Terminal 1	(Feedback #1)
Signal:	"Open Valve"	Terminal 2	(Feedback #2)
Signal:	"Seat-lift 1"	Terminal 3	(Feedback #3)
Signal:	"Seat-lift 2"	Terminal 4	(Feedback #4)
Signal:	"Status"	Terminal 5	(Feedback #5)

For wire connections: See 5.4 Electrical connection, internal

Note: If the programmer wishes to detect a physical closed valve position in an "Open Valve" sensor position, then there is no longer any consistence between the sensor valve detection position and the visual indications of the ThinkTop.

Status signal (Feedback # 5)

The status signal is used for four purposes:

- To indicate that setup is in progress + (LED D).
- To indicate an error condition + (LED D). (Flashing LED = software error), (steady LED = hardware error).
- To indicate maintenance due to the self adjustment programme + (LED F).
- To indicate that the time for maintenance has been reached + (LED F).

Technical specifications solenoid valves

Solenoid valve signals

Three output signals (with one common, terminal 11) from the terminal row are used for activation of the solenoids. Depending on the PLC used, the common could be either positive (connected with terminal 9) or negative for DC voltage. The signals are galvanically isolated from the sensor circuits.

Internal connections

Terminals for wire connection of the solenoids mounted internally in the control head. The number of solenoids actually mounted in the control head could be 0 - 3. The signals are taken directly from the terminal row.

Technical specifications		
Up to 3 solenoid valves in each unit.		
Type		3/2 or 5/2 valve (only possible with one 5/2 valve).
Air supply		300-900 kPa (3-9 bar).
Filtered air, max. particles or dirt		5 μ 5-5 mg/m ³ .
Max. flow		180 l/min.
Max. oil content		1 mg/m ³ .
Max. water content		0.88 g/m ³ -20 °C compressed air.
Throughput		ø2.5 mm.
Air restriction (throttle function) air inlet/outlet.		Yes.
Manual hold override.		Yes.
External air tube connection		ø6 mm or 1/4" (specify when ordering).
Silencer/filter		Connection possible via ø6 mm or 1/4". (Filter recommended in tropical regions).
Nominal voltage		24 VDC.
Nominal power		1.0 W.
Materials		
Plastic parts		Nylon PA12.
Steel parts		Stainless steel AISI 304 and 316.
Seals		Nitrile (NBR), EPDM rubber for SMP-EC activator stem.
Gore vent. membrane		PBT plastic.

Micro environment demand specifications

Temperature		
Working:	-20°C to +85°C	IEC 68-2-1/2
Storage:	-40°C to +85°C	IEC 68-2-1/2
Temperature change:	-25°C to +70°C	IEC 68-2-14
Vibration		
	10-55 Hz, 0.7 mm	IEC 68-2-6
	55-500 Hz, 10g	
	3 x 30 min, 1 octave/min	
Drop test		
		IEC 68-2-32
Humidity		
Constant humidity:	+40°C, 21 days, 93% R.H.	IEC 68-2-3
Cyclic humidity:	+25°C/+55°C	
	12 cycles	IEC 68-2-30
(working)	93% R.H.	
Protection class		
	IP66 and IP67	IEC 529
Input treshold		
Voltage/current:	Type 1 input requirements	EN 61131-2
Solenoid signals		
Isolation voltage	(1000 + 2 x 117) VAC rms/1 min	EN 61131-2
EMC Directive		
	2004/108/EF	EN 61000-6-3, EN 61000-6-2
UL Approval		
	8-30 VAC/VDC, Class 2 input, 45 mA max. output	UL 508-E203255

5 Installation

5.1 Installation on air actuators

Step 1



Always read the technical data thoroughly.



Always have the ThinkTop electrically connected by authorized personnel.

Step 2

1. Fit the air fittings on actuator if not mounted.
2. Fit the activator stem (magnet) and tighten **carefully** with a spanner.

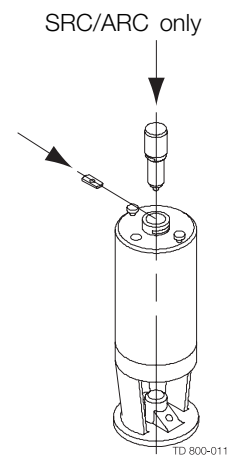

Step 3

1. Place the ThinkTop on top of the actuator.
2. Make sure X-ring is mounted.

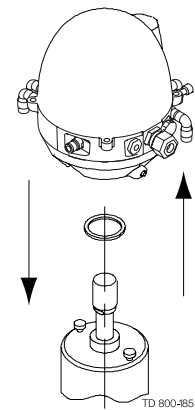

Step 4

1. Ensure that the unit is correctly mounted by **pressing** down on top of the ThinkTop.
2. Tighten the two Allen screws **carefully** (1.50 Nm).
3. Turn the actuator to have LEDs in a front view.

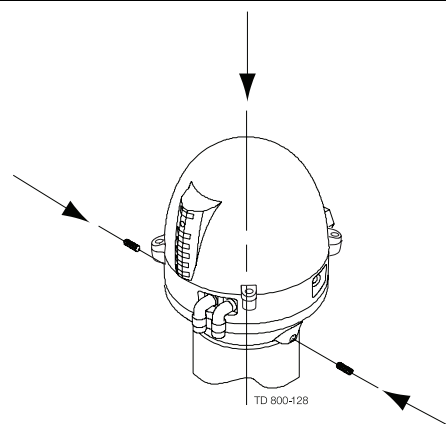

Step 5

Fit the $\varnothing 6$ mm (1/4") air tubes to ThinkTop
(see drawing "Air connections" page 16).

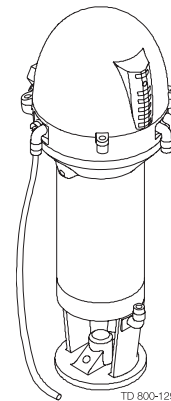

Step 6

Fit the air tubes to the actuator
(see drawing "Air connections" page 16).

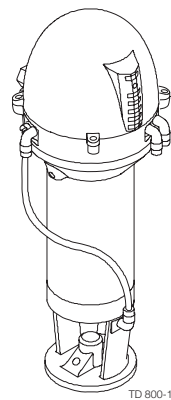

Step 7

Uptighten the four screws and pull off cover of ThinkTop.

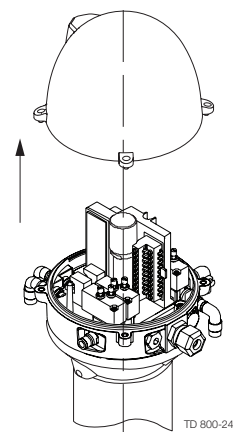

Step 8

1. Install cable (if not present) through the cable gland.
2. Connect the ThinkTop electrically
(see page17 "Electrical connection, internal").

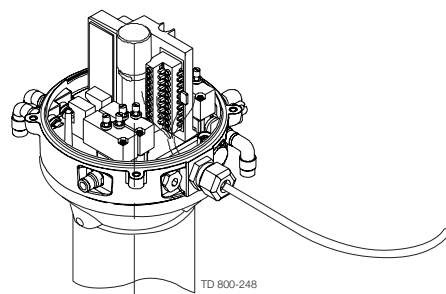

5 Installation

Step 9

Make sure the cable gland is completely tightened.

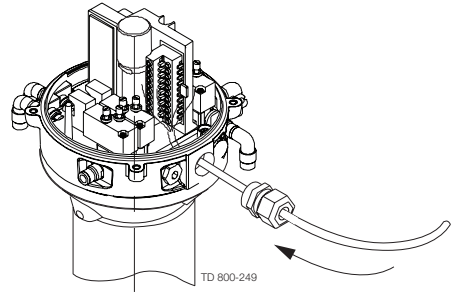

Step 10

Set up the ThinkTop (see chapter 6 Setup diagram).

NOTE!

The unit can be set up with the cover installed by using the IR keypad. To energize the valve, use a separate air tube or be in radio contact with the control room.

5.2 Installation on Series 700 valves

Step 1

1. Remove the cover by loosening the four cover screws.
2. Separate the adapter from the base by loosening the three recess screws on top of the base.

Installation on air actuators:

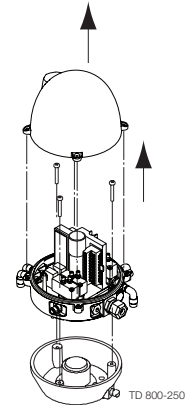

Step 2

1. Fit air fittings on actuator.
2. Position packing retainer in recess on actuator top.
3. Fit counter nut and indication pin (magnet) on actuator rod. Engage approx. 1/4" thread. Tighten counter nut and indicator with two wrenches.

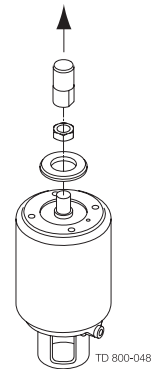

Step 3

1. Place the two O-rings in the grooves in the bottom of the adapter. Then place the adapter on the actuator top. The small O-ring must be positioned over the air hole on the actuator.
2. Fasten the adapter with the four 5/16" Allen screws.

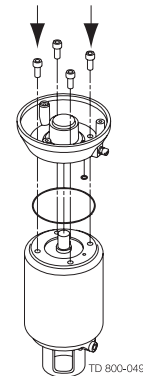

Step 4

Mount the base on the adapter in the position needed (can be rotated 120° in both directions). Note that one of the screw towers on the adapter has a guide recess (see * on drawing).

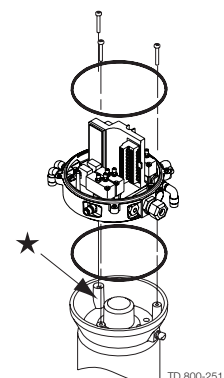

5 Installation

5.3 Air connections

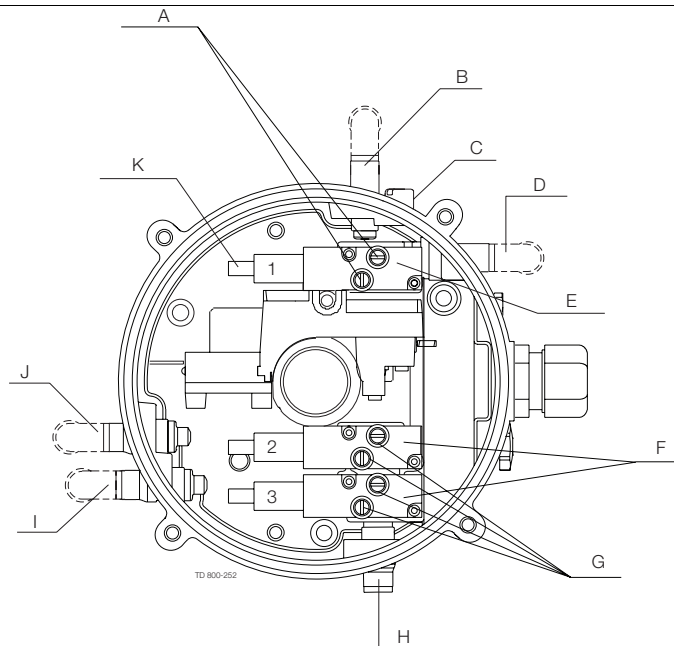

- A. Air restriction (throttle function) air inlet/outlet
 - B. Air out 1A
 - C. Air exhaust
 - D. Air out 1B (5/2 port solenoid valve only)
 - E. Solenoid 3/2 or 5/2
 - F. 3/2 Solenoid valves only
 - G. Air restriction (throttle function) air inlet/outlet
 - H. Air in
 - I. Air out 3
 - J. Air out 2
 - K. Manual hold override
-

5.4 Electrical connection, internal

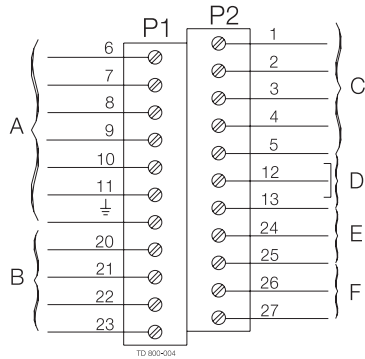

A	Digital interface command signals	D	Jumper connections **)
B	Internal connections to solenoid 1-3 ***)	E	Incoming signals from external sensors ****)
C	Feedback signals to digital interface	F	Supply to external sensors *)

6	Solenoid 1	1	Closed valve
7	Solenoid 2	2	Open valve
8	Solenoid 3	3	Seat-lift 1
9	Supply +	4	Seat-lift 2
10	Supply -	5	Status
11	Solenoid com Earth	12	NPN/PNP Jumper **)
20	Solenoid common blue	13	NPN/PNP Jumper **)
21	Solenoid 1, brown	24	Seat-lift 1 "upper" *)
22	Solenoid 2, brown	25	Seat-lift 2 "lower" *)
23	Solenoid 3, brown	26	Supply + *)
		27	Supply - *)

Table 1. Note!

- *) Terminals 24, 25, 26 and 27 can be used for external seat lift sensors as well as for any digital input. Always use an external PNP sensor. Two external signals can be connected, they are associated with feedback signal 3 (seat-lift 1) and 4 (seat-lift 2). External sensor must always be a 8-30 VDC PNP 3 wire sensor. Connect (-) common on terminal 27, and (+) common on terminal 26. The signals from the external sensors are associated as follows: sensor signal on terminal 24 (seat-lift 1) associated with feedback 3 (seat-lift 1), and sensor signal on terminal 25 (seat-lift 2) associated with feedback 4 (seat-lift 2).
- ***) Jumper present = PNP. If changing the function a power recycle is necessary. The selection NPN/PNP is done by the jumper.
- ****) Internal connections: Terminals for connection for the solenoids mounted internally in the control head. The number of solenoids actually mounted in the control head could be 0 - 3. The signals are taken directly from the terminal row.
- *****) If using external sensor, the sensor must be active/activated when performing a set-up routine of the control head.

Note! Remember to isolate wires that are not in use.

5 Installation

5.5 Example of connecting power supplies

When using one power supply for sensor system and solenoid valves:

Example of connecting power supplies

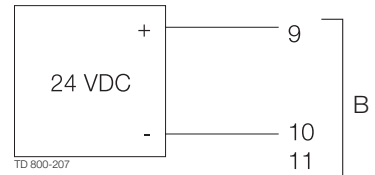
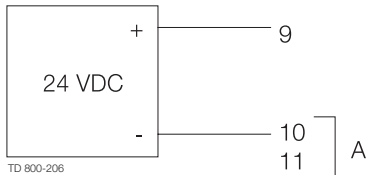

A. Jumper if positive activation of solenoids

B. Jumper if negative activation of solenoids

When using two power supplies, one for sensor board and one for the solenoid valves:

Sensor System:

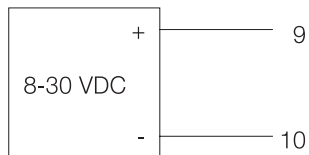

Solenoid Valves:

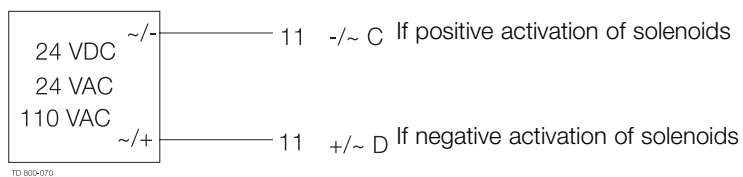

6.1 ThinkTop setup utilising IR keypad

General

Flashing LED means no value set. Steady LED means value set as shown

Default: Step 2, Factory set tolerance band +/- 5mm
Step 3-8, disabled

D LED: Active during set-up: Flashing in step 1
Steady in all other steps

Or during operations, error condition: Steady showing hardware fault, indication pin out of range
Flashing showing software fault

Timeout: A 60 sec. timeout is started as soon as any button(s) are released
On timeout the setup is exited with no changes saved

IR Keypad: Remote distance 0-300 mm to ThinkTop

Symbols

Push key on IR keypad with the same number

Simple representation of LED indication:

Yellow	B	<input type="checkbox"/>	
IR-Receiver		<input type="radio"/>	
Red	D	<input checked="" type="checkbox"/>	Steady LED
Yellow	C	<input type="checkbox"/>	
Green	E	<input type="checkbox"/>	
Orange	F	<input type="checkbox"/>	
Yellow	A	<input checked="" type="checkbox"/>	Flashing LED



General commands in each step (except step 1):

- | | | |
|----------------------------|-----------------------|---|
| <input type="checkbox"/> 0 | Next step / skip step | (In step 3-6 the program automatically moves to the next step when a position is stored) |
| <input type="checkbox"/> 5 | Clear / disable step | (In step 2 this resets the unit and set the step 2-8 to default)
(The command is accepted when all unit LED's flash briefly) |

**It is recommended to reset the unit before
performing a setup
Always check for correct signals after the setup**

6 Setup diagram

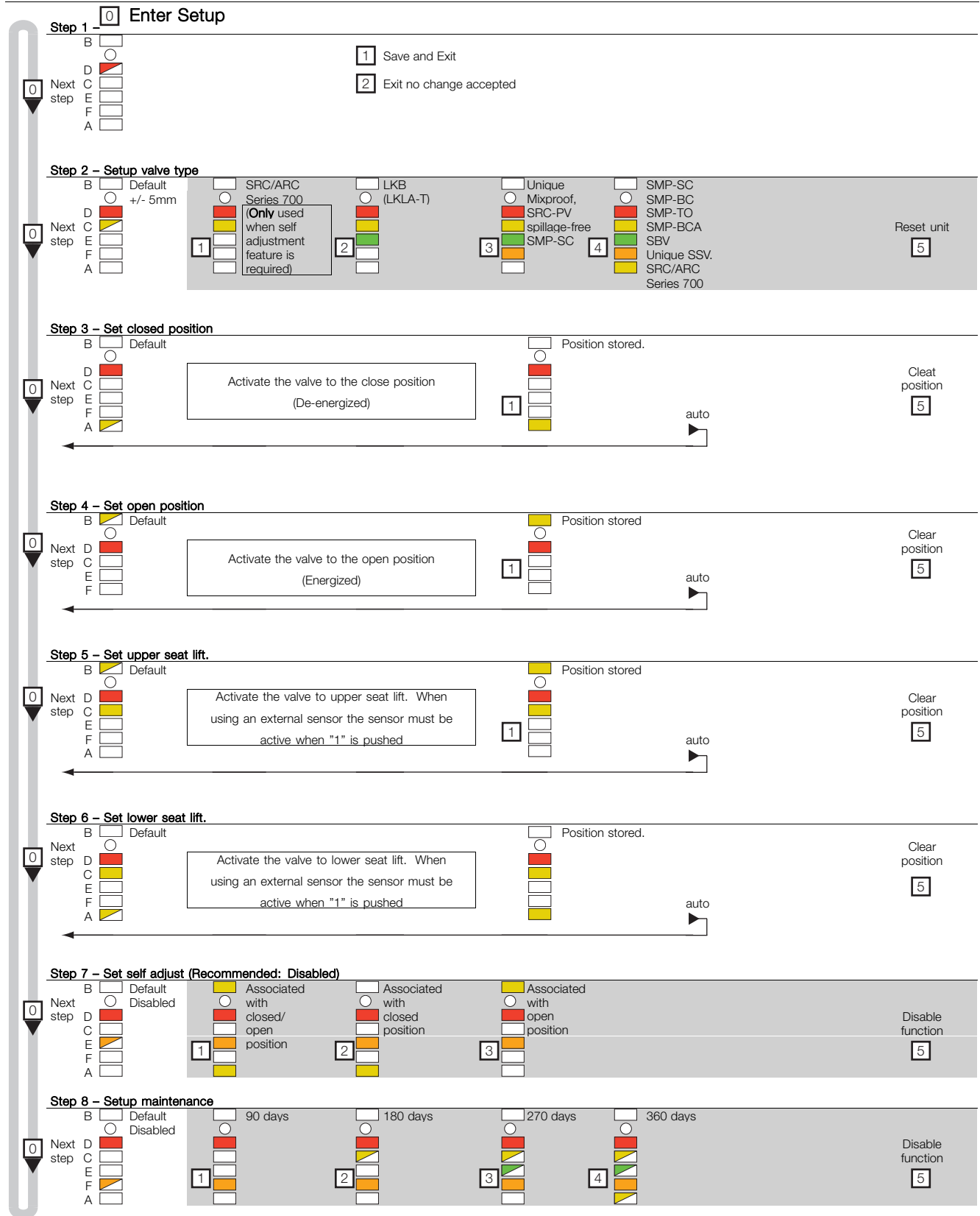

6.2 ThinkTop setup utilising local 'I' and 'II' keys

General

Default is: Step 2, tolerance is +/- 5mm
Step 3-8, disabled

Timeout: A 60 sec. timeout is started as soon as any button(s) are released
On timeout the setup is exited with no changes saved

Flashing LED means no value set. Steady LED means value set as shown
[D] LED: Active during set-up: Flashing in step 1
Steady in all other steps

Or during operations, error condition: Steady showing hardware fault, indication pin out of range
Flashing showing software fault

General commands in each step (except step 1):

ⓘ	Next step / skip step	(In step 3-6 the program automatically moves to the next step when a position is stored)
ⓘ _{5s}	Clear / disable step	(In step 2 this resets the unit to default) (The command is accepted when all unlit LED's flash briefly)

It is recommended to reset the unit before performing a setup

Symbols

ⓘ	Push local key "I"
ⓘ	Push local key "II"
ⓘ _{5s}	Hold key "II" for 5 sec

Simple representation of LED indication:

Yellow	B	<input type="checkbox"/>	
IR-Receiver		<input type="radio"/>	
Red	D	<input checked="" type="checkbox"/>	Steady LED
Yellow	C	<input type="checkbox"/>	
Green	E	<input type="checkbox"/>	
Orange	F	<input type="checkbox"/>	
Yellow	A	<input type="checkbox"/>	Flashing LED



6 Setup diagram

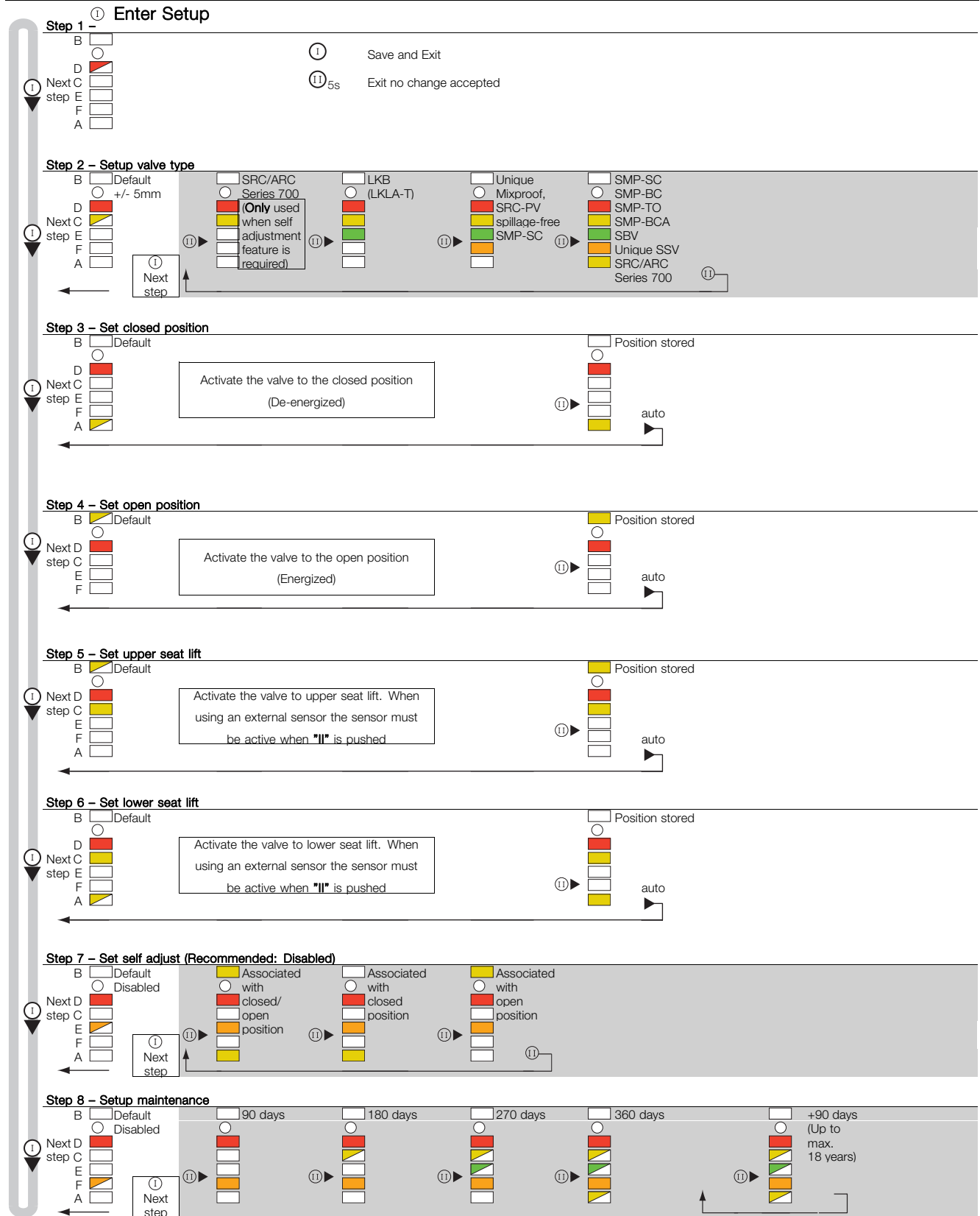

6.3 ThinkTop quick setup guide

Valve: Unique SSV, SRC/ARC type NC (selfadjustment disabled)

Push:	I	- and wait until red LED flashes
Push:	I	
Push:	II	- hold for 5 sec (clear all stored parameters)
Push:	II	(red + yellow LED)
Push:	II	(red + yellow + green LED)
Push:	II	(red + yellow + green + orange LED)
Push:	II	(red + yellow + green + orange + yellow LED)
Push:	I	
Push:	II	- to approve valve down (closed)
Activate		Valve opens
Push:	II	- to approve (open)
Push:	I	(no upper seat-lift)
Push:	I	(no lower seat-lift)
Push:	I	(no self adjustment)
Push:	I	(no maintenance)
Push:	II	Red LED flashes (save & exit by push)



Setup
done

Valve: SRC/ARC type NO (selfadjustment enabled)

Push:	I	- and wait until red LED flashes
Push:	I	
Push:	II	- hold for 5 sec (clear all stored parameters)
Push:	II	(red + yellow LED)
Push:	I	
Activate		Valve closes
Push:	II	- to approve valve closed
Push:	Deactivate	Valve opens
Push:	II	- to approve valve is open
Push:	I	(no upper seat-lift)
Push:	I	(no lower seat-lift)
Push:	II	= self adjustment
Push:	I	
Push:	I	(no maintenance)
Push:	II	Red LED flashes (save & exit by push)



Setup
done

Valve: LKB Valve (Butterfly) NC

Push:	I	- and wait until red LED flashes
Push:	I	
Push:	II	- hold for 5 sec
Push:	II	(red + yellow LED)
Push:	II	(red + yellow + green LED)
Push:	I	
Push:	II	- to approve valve closed (indication stem up)
Push:	Activate	LKB valve- open position (indication-stem down)
Push:	II	- to approve valve is open
Push:	I	(no upper seat-lift)
Push:	I	(no lower seat-lift)
Push:	I	(no self adjustment)
Push:	I	(no maintenance)
Push:	II	Red LED flashes (save & exit by push)



6 Setup diagram

Setup done

Valve: LKB Valve (Butterfly) NO

Push:	I	- and wait until red LED flashes
Push:	I	
Push:	II	- hold for 5 sec (clear all stored parameters)
Push:	II	(red + yellow LED)
Push:	II	(red + yellow + green LED)
Push:	I	
	Activate	- to approve valve closed (indication stem up)
Push:	II	- to approve valve closed
Push:	Deactivate	LKB valve-open position (indication-stem up)
Push:	II	- to approve valve is open
Push:	I	(no upper seat-lift)
Push:	I	(no lower seat-lift)
Push:	I	(no self adjustment)
Push:	I	(no maintenance)
Push:	II	Red LED flashes (save & exit by push)
	Setup done	



Valve: Unique mixproof Valve (with lower seat-lift)

Push:	I	- and wait until red LED flashes
Push:	I	
Push:	II	- hold for 5 sec (clear all stored parameters)
Push:	II	(red + yellow LED)
Push:	II	(red + yellow + green LED)
Push:	II	(red + yellow + green + orange LED)
Push:	I	
Push:	II	- to approve valve closed
	Activate	Valve opens
Push:	II	- to approve valve is open
Push:	Activate	Lower seat-lift active
Push:	II	- to approve
Push:	I	(no self adjustment)
Push:	I	(no maintenance)
Push:	II	Red LED flashes (save & exit by push)
	Setup done	



7 Fault finding

7.1 Fault finding and LEDs

Below is stated the meaning of the LEDs' indications for fault finding in connection with the operation of the ThinkTop.

<div style="border: 1px solid black; width: 30px; height: 15px; margin-bottom: 5px;"></div> <div style="text-align: center; margin-bottom: 5px;">○</div> <div style="background-color: #cccccc; border: 1px solid black; width: 30px; height: 15px; margin-bottom: 5px; display: flex; align-items: center; justify-content: center; font-size: 8px;">Red</div> <div style="border: 1px solid black; width: 30px; height: 15px; margin-bottom: 5px;"></div> <div style="border: 1px solid black; width: 30px; height: 15px; margin-bottom: 5px;"></div> <div style="border: 1px solid black; width: 30px; height: 15px; margin-bottom: 5px;"></div> <div style="border: 1px solid black; width: 30px; height: 15px;"></div>	<p>Red flashing: Unit in set-up mode or internal software fault. If internal software fault, re-programme unit.</p> <p>Red steady: Unit in set-up mode or internal hardware fault. If internal hardware fault, check if magnet is in range and check correct wiring.</p>
---	--

<div style="background-color: #cccccc; border: 1px solid black; width: 30px; height: 15px; display: flex; align-items: center; justify-content: center; font-size: 8px;">Yellow B</div> <div style="text-align: center; margin-bottom: 5px;">○</div> <div style="border: 1px solid black; width: 30px; height: 15px; margin-bottom: 5px;"></div> <div style="border: 1px solid black; width: 30px; height: 15px; margin-bottom: 5px;"></div> <div style="border: 1px solid black; width: 30px; height: 15px; margin-bottom: 5px;"></div> <div style="background-color: #cccccc; border: 1px solid black; width: 30px; height: 15px; display: flex; align-items: center; justify-content: center; font-size: 8px;">Orange</div> <div style="background-color: #cccccc; border: 1px solid black; width: 30px; height: 15px; display: flex; align-items: center; justify-content: center; font-size: 8px;">Yellow A</div>	<p>1. Orange flashing: Time for maintenance has run out. The unit has been self-adjusted into a maintenance alert condition. Valve maintenance is strongly recommended. After maintenance: Disabling of maintenance/self-adjustment function is required before setting new position, however, it is strongly recommended to make a complete new set-up after valve maintenance.</p> <p>2. Orange steady, yellow flashing (A and/or B): The unit has been self-adjusted into a maintenance alarm condition and the feedback is lost (a minimum of seal left). Valve maintenance is required. After maintenance: Disabling of the self-adjustment function is required before setting new position, however, it is strongly recommended to make a complete new set-up after valve maintenance.</p> <p>NOTE! The maintenance indicator lighting up, and an open or closed light flashing..... = Note the following:</p> <ul style="list-style-type: none"> - Self-adjustment programme is only valid for SRC/ARC valves, do not use the programme for other valve types. - Use tolerance/valve type 1. - In conjunction with valve type change-over; 21, 22, 31 and 32, the open position must be defined as the upper sensor position (when the indication pin is in the highest position). - A loose top, indication pin or sensor system can also generate the alert/alarm condition. - Removing a ThinkTop with self-adjust activated, will immediately generate an alarm condition! If the ThinkTop has to be removed, not because of a valve maintenance issue, but for some other reasons, and you want to store the already adjusted data - disable the self-adjust function before removing the ThinkTop and enable it again once the ThinkTop is back on the actuator. - After valve maintenance a disabling of the self-adjustment function is required before setting a new position, however, it is strongly recommended to make a complete new set-up (disable all functions in step 2 valve type - and make a complete new set-up).
--	--

<div style="border: 1px solid black; width: 30px; height: 15px; margin-bottom: 5px;"></div> <div style="text-align: center; margin-bottom: 5px;">○</div> <div style="border: 1px solid black; width: 30px; height: 15px; margin-bottom: 5px;"></div> <div style="border: 1px solid black; width: 30px; height: 15px; margin-bottom: 5px;"></div> <div style="border: 1px solid black; width: 30px; height: 15px; margin-bottom: 5px;"></div> <div style="border: 1px solid black; width: 30px; height: 15px; margin-bottom: 5px;"></div> <div style="border: 1px solid black; width: 30px; height: 15px; margin-bottom: 5px;"></div> <div style="background-color: #cccccc; border: 1px solid black; width: 30px; height: 15px; display: flex; align-items: center; justify-content: center; font-size: 8px;">Yellow A</div>	<p>Yellow steady: Position A (closed valve).</p>
--	---

Yellow B Yellow steady: Position B (open valve).



Yellow steady: Position C (Seat lift 1-2 or external sensors).



Yellow C



Green Green steady: Solenoid valves energized.

Note! During set-up LED lights have different functions.

8 Maintenance

Study the instructions carefully.

Handle scrap correctly.

Always keep spare X-rings in stock.

8.1 Dismantling of ThinkTop

Step 1

1. Untighten the two Allen screws and remove the ThinkTop from the actuator.
2. Pull out X-ring (19) and replace it.

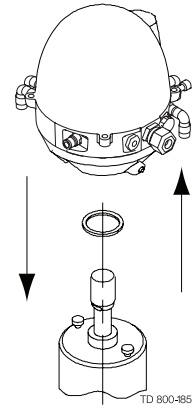

Step 2

1. Untighten the four screws.
2. Pull off cover of ThinkTop.
3. Remove X-ring (9) (grey).

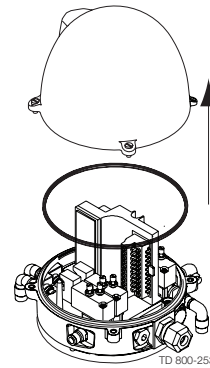

Step 3

1. Untighten screws.
2. Remove solenoid valves (up to three) and replace them with new ones.

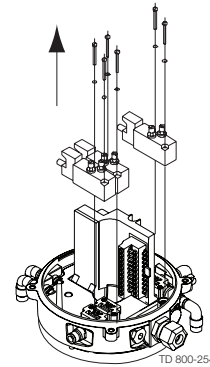

Step 4

1. To dismantle the adapter (the lower part of the ThinkTop) from base (the middle part), unscrew the three screws.
2. Turn the lower part a little clockwise and pull.
3. Replace adapter if necessary.
4. Remove the black X-ring.

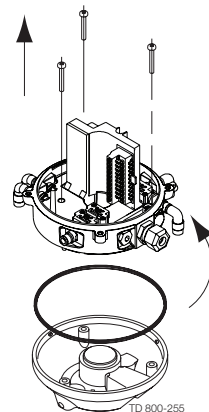

Note:
Turn banjo connection!

*Study the instructions carefully.
Handle scrap correctly.
Always keep spare X-rings in stock.*

Step 5

To remove the sensor unit untighten screw and pull out the sensor unit.

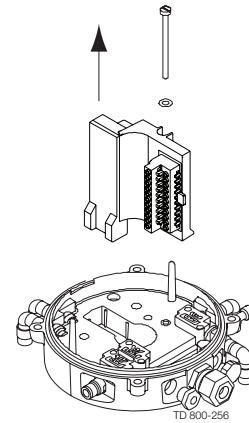

8 Maintenance

Study the instructions carefully.

Handle scrap correctly.

Always keep spare X-rings in stock.

8.2 Assembly of ThinkTop

Step 1

Place sensor unit in base and tighten screw (torque: 1 Nm).

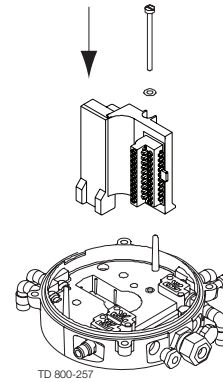

Step 2

1. Replace the black X-ring.
2. Assemble base with adapter by turning adapter slightly anticlockwise and tighten the four screws (1.9 Nm).

CAUTION!

Do NOT twist the X-ring in the groove!

The X-ring is not square. The highest (h) part must be placed as fig.

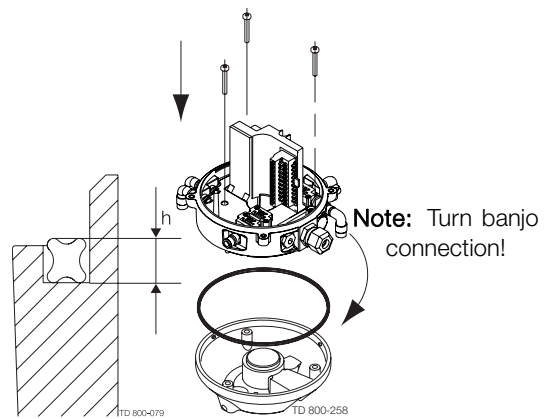

Step 3

1. Replace solenoid valves (up to three) with new ones.
2. Tighten screws (0.2 Nm).

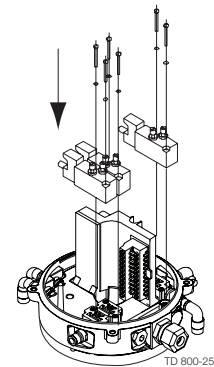

Step 4

1. Replace the grey X-ring.
2. Replace cover of ThinkTop and tighten the four screws (0.6 Nm).

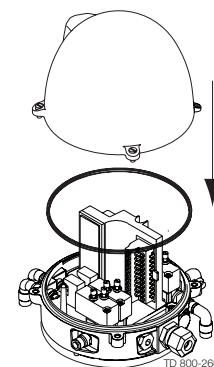

*Study the instructions carefully.
Handle scrap correctly.
Always keep spare X-rings in stock.*

Step 5

- 1. Replace the black X-ring.
- 2. Mount ThinkTop on actuator.

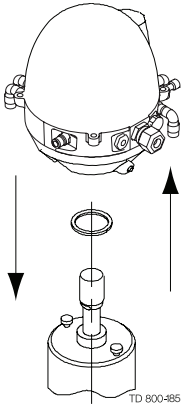

8 Maintenance

Study the instructions carefully.

Handle scrap correctly.

Always keep spare X-rings in stock.

8.3 Dismantling and assembly of Series 700 valves

Step 1

1. Remove the cover by loosening the four cover screws.
2. Separate the adapter from the base by loosening the three recess screws on top of the base.

Installation on air actuators:

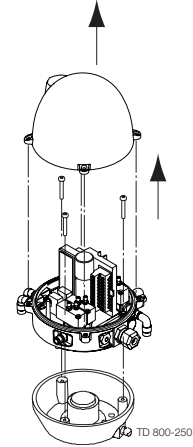

Step 2

1. Fit air fittings on actuator.
2. Position packing retainer in recess on actuator top.
3. Fit counter nut and indicator (magnet) on actuator rod. Engage approx. 1/4" thread. Tighten counter nut and indicator with two wrenches.

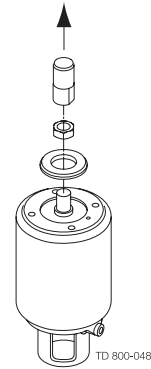

Step 3

1. Place the two O-rings in the grooves in the bottom of the adapter. Then place the adapter on the actuator top. The small O-ring must be positioned over the air hole on the actuator.
2. Fasten the adapter with the four 5/16" Allen screws.

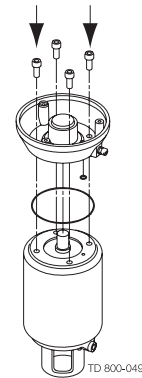

Step 4

1. Mount the base on the adapter in the position needed (can be rotated 120° in both directions). Note that one of the screw towers on the adapter has a guide recess (see * on drawing).
2. Remove x-rings (9) (grey) and (16) (black).
3. Replace with new ones.

CAUTION! Do NOT twist the X-ring in the groove! The X-ring is not square; The highest (h) part must be placed as fig.

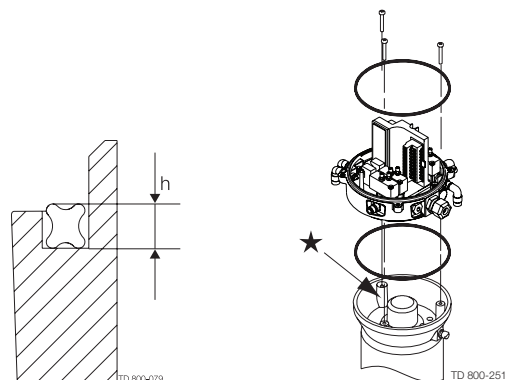

The drawings show ThinkTop Digital 8-30 VDC PNP/NPN.
 The items refer to the parts lists in the following sections

9.1 Drawings for ThinkTop Digital VDC

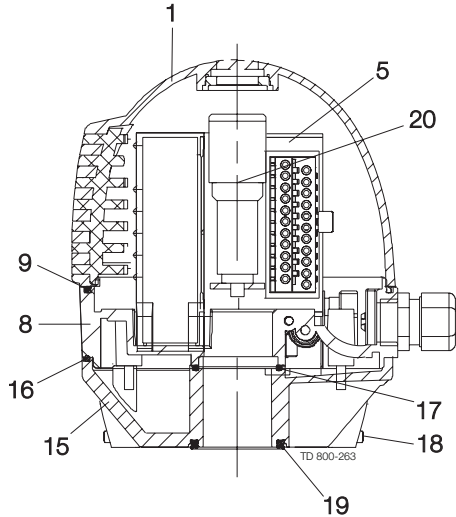
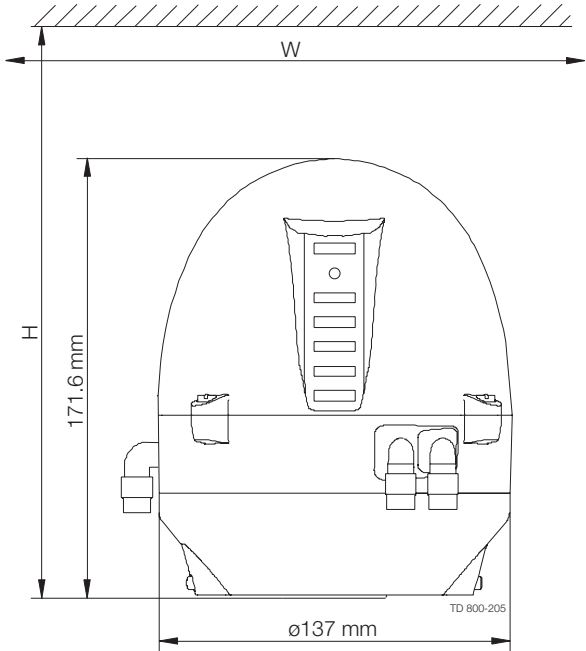

Note! This is the basic design.

Valve Type	H	W
Unique SSV NC	225	250
SMP-SC/-BC/-TO	225	250
Unique Mixproof	225	250
MH	225	250
SBV	225	250
Unique SSV NO	225	320
LKLA-T	225	300

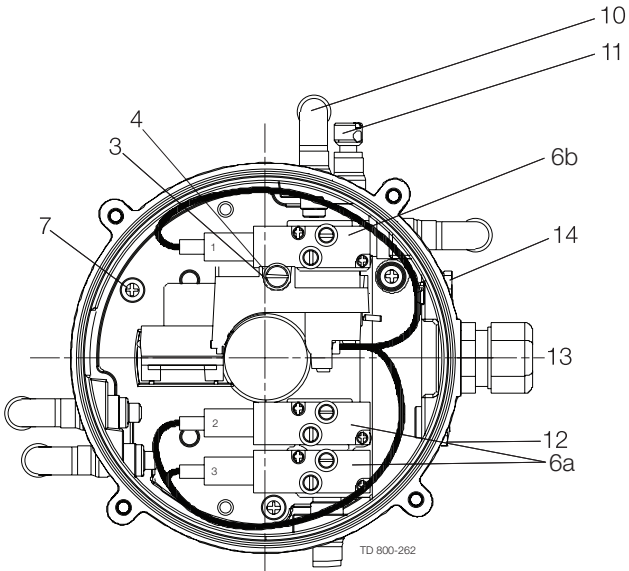

9 Parts list and Service Kits

The drawings show ThinkTop Digital 8-30 VDC PNP/NPN.
The items refer to the parts lists in the following sections

9.2 ThinkTop Digital VDC

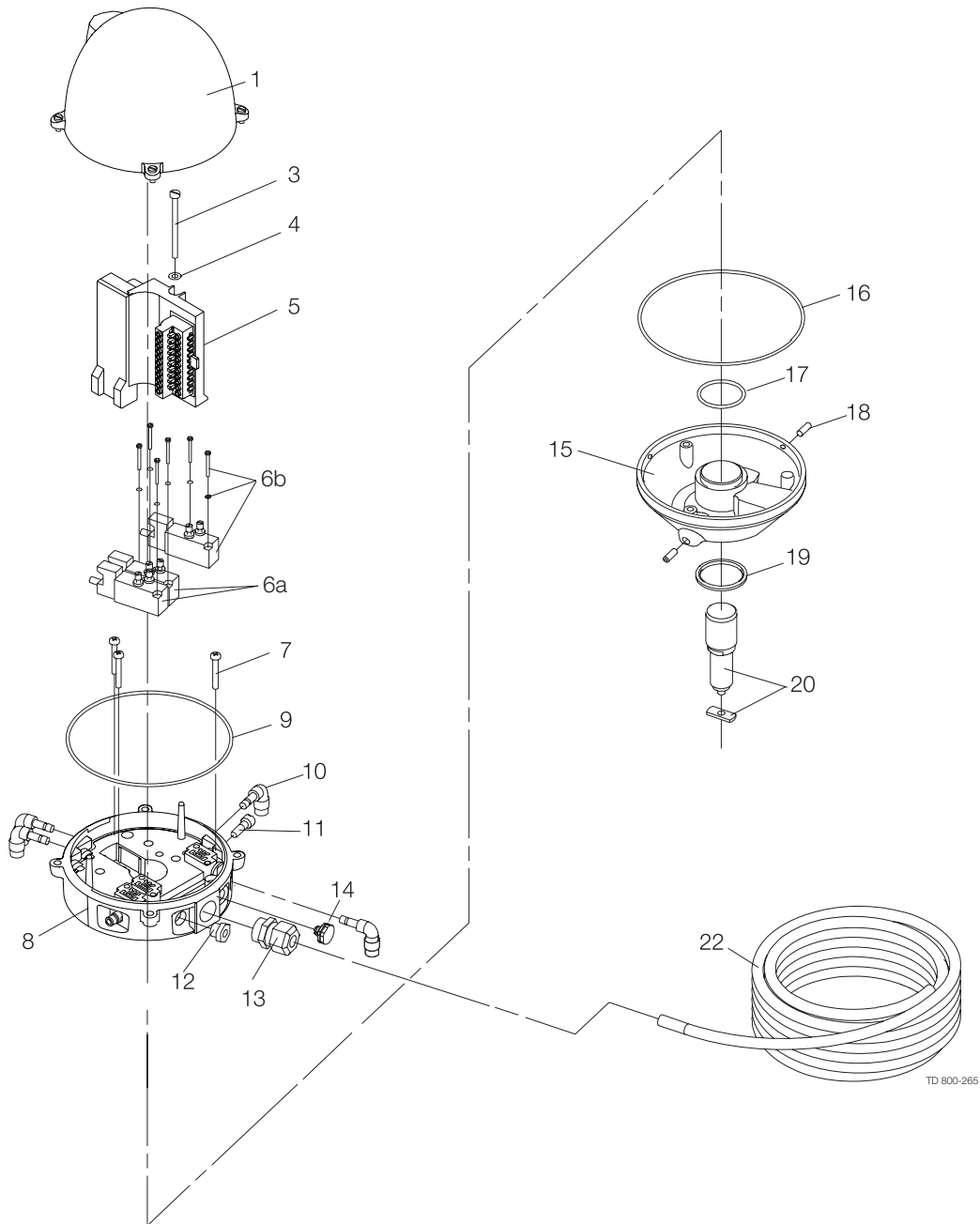

TD 800-265

The drawings show ThinkTop Digital 8-30 VDC PNP/NPN.

The items refer to the parts lists in the following sections

Parts list

Pos.	Qty	Denomination
		(Pos.9,12,13,14 included)
1	1	Shell complete
3	1	Screw
4	1	Washer
5	1	Sensor board
6a	1-3	Solenoid valve
7	3	PT screw
8	1	Base
9	1	Special X-ring, grey
10	1	Air fitting
11	1	Blow-off valve
12	1	Thread plug, PG7 ø3-ø6.5 mm
13	1	Cable gland, PG11 ø4-ø10 mm
14	1	Gore vent High airflow
15	1	Adapter complete
16	1	Special X-ring, black
17	1	O-ring
18	2	Allen screw
19	1	Special X-ring
20	1	Indication pin
22	1	5 m flying PVC cable (12 x 0.5 mm ²) Digital

Service kits

Solenoid valve 3/2, 24 VDC	9611-99-3324
Solenoid valve 5/2, 24 VDC	9611-99-3327
Solenoid valve 3/2, 24 VAC	9611-99-3325
Solenoid valve 3/2, 110 VAC	9611-99-3326
Solenoid valve 5/2, 24 VAC	9611-99-3328
Solenoid valve 5/2, 110 VAC	9611-99-3329
Indication pin	9612-5623-01
Special indication pin, SRC-LS	9612-6370-01
Special indication pin, Unique SSV-LS	9613-1581-01
Special indication pin, Unique SSV High Pressure	9613-1581-01
Air fitting, Ø6 mm	9611-99-3405
Air fitting, 1/4"	9611-99-3433
Gore vent	9611-99-4722
X-ring, pos. 9	9613-4564-01
X-ring, pos. 16	9612-9994-01
X-ring, pos. 19	9612-5696-01
Sensor board Digital 8-30 VDC PNP/NPN (Period -0902	9612-5627-01
Sensor board Digital 8-30 VDC PNP/NPN (Period 0902-)	9613-4434-01

9 Parts list and Service Kits

The drawings show ThinkTop Digital 8-30 VDC PNP/NPN Series 700 valves.
 The items refer to the parts lists in the following sections

9.3 Drawings for ThinkTop VDC for Series 700

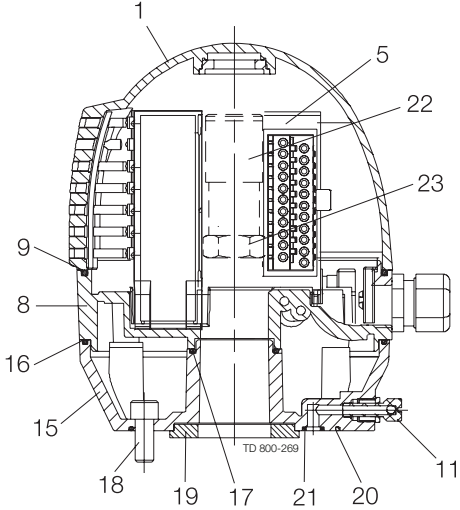
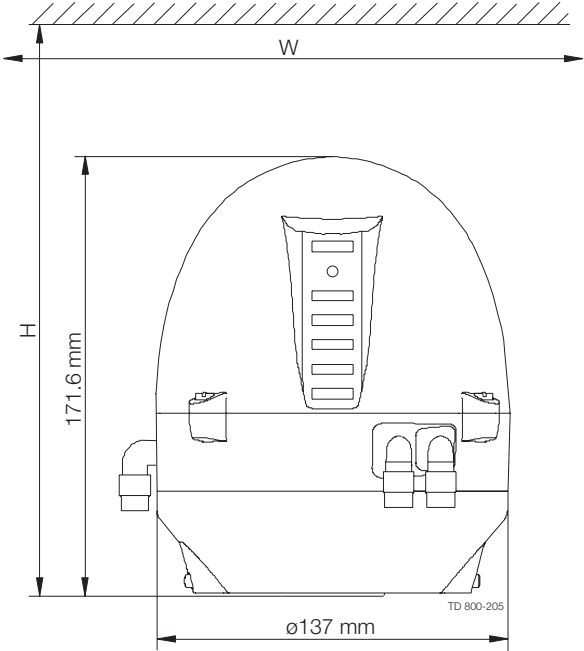

Note! This is the basic design.

Valve Type	H	W
Unique SSV NC	225	250
SMP-SC/-BC/-TO	225	250
Unique Mixproof	225	250
MH	225	250
SBV	225	250
Unique SSV NO	225	320
LKLA-T	225	300

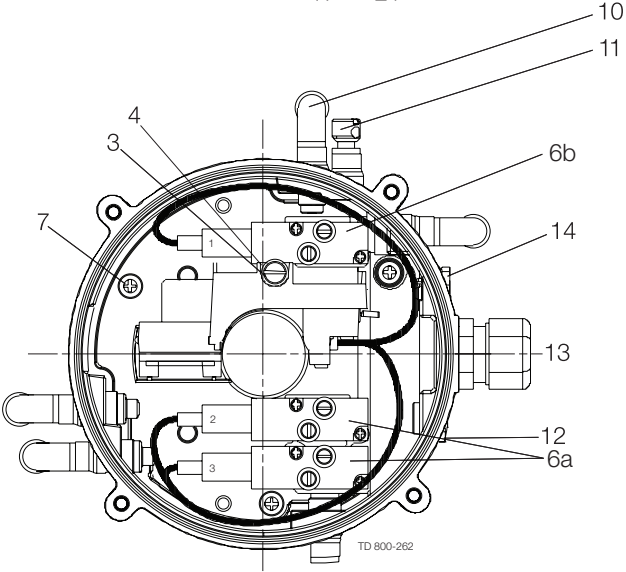

9 Parts list and Service Kits

The drawings show ThinkTop Digital 8-30 VDC PNP/NPN Series 700 valves.
The items refer to the parts lists in the following sections

9.4 ThinkTop VDC for Series 700

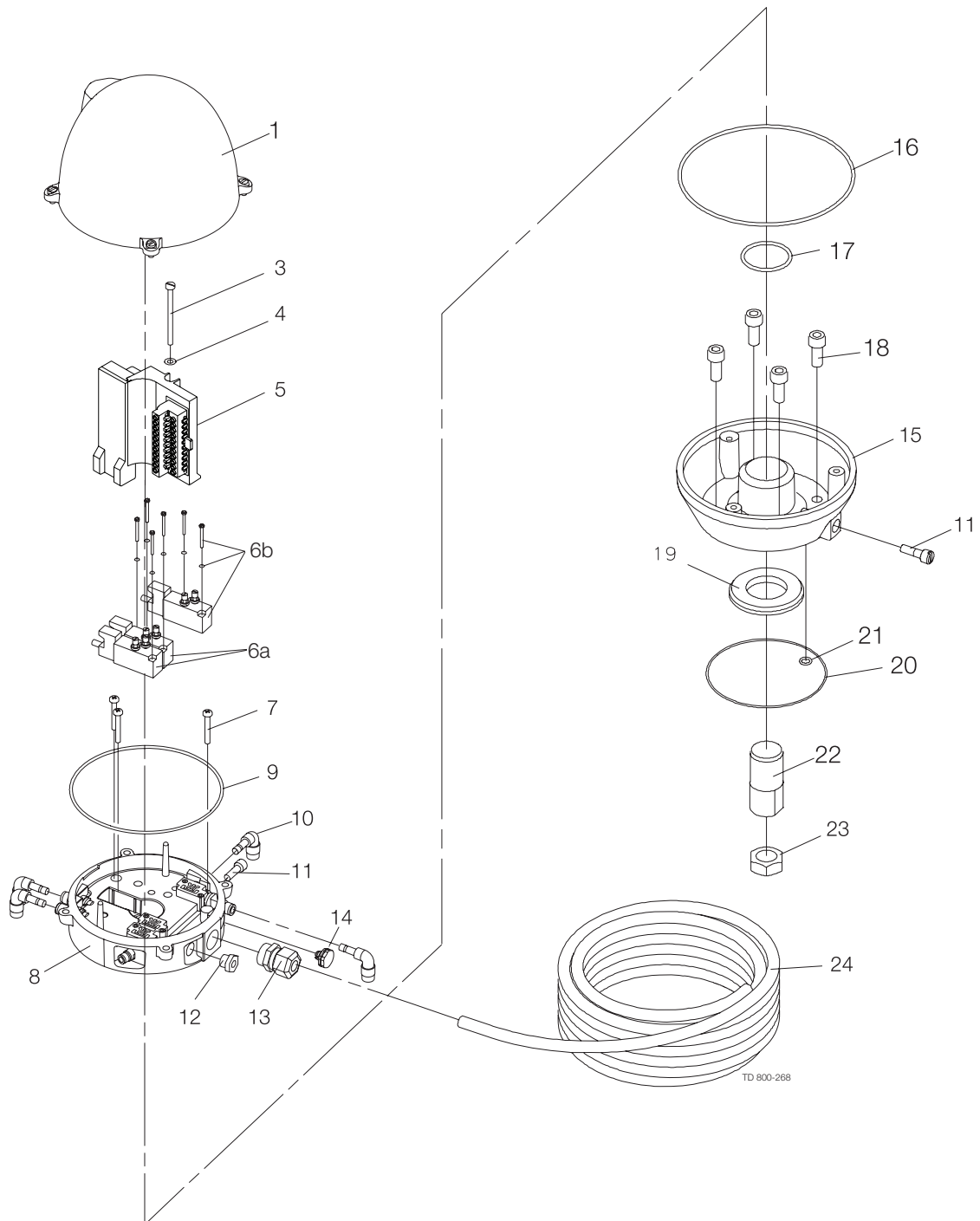

9 Parts list and Service Kits

The drawings show ThinkTop Digital 8-30 VDC PNP/NPN Series 700 valves.
The items refer to the parts lists in the following sections

Parts list

Pos.	Qty	Denomination
		(Pos.9,12,13,14 included)
1	1	Shell complete
3	1	Screw
4	1	Washer
5	1	Sensor board
6a	1-3	Solenoid valve
7	3	PT screw
8	1	Base
9	1	Special X-ring, grey
10	1	Air fitting
11	2	Blow-off valve
12	1	Thread plug, PG7 ø3-ø6.5 mm
13	1	Cable gland, PG11 ø4-ø10 mm
14	1	Gore vent High airflow
15	1	Adapter complete
16	1	Special X-ring, black
17	1	O-ring
18	4	Screw
19	1	Retainer
20	1	O-ring
21	1	O-ring
22	1	Indicator pin
23	1	Nut
24	1	5 m flying PVC cable (12 x 0.5 mm ²) Digital

Service kits

Solenoid valve 3/2, 24 VDC	9611-99-3324
Solenoid valve 5/2, 24 VDC	9611-99-3327
Solenoid valve 3/2, 24 VAC	9611-99-3325
Solenoid valve 3/2, 110VAC	9611-99-3326
Solenoid valve 5/2, 24 VAC	9611-99-3328
Solenoid valve 5/2, 110 VAC	9611-99-3329
Indication pin	9612-6357-02
Air fitting, 1/4"	9611-99-3433
Gore vent	9611-99-4722
X-ring, pos. 9	9613-4564-01
X-ring, pos. 16	9612-9994-01
Sensor board Digital 8-30 VDC PNP/NPN (Period -0902	9612-5627-01
Sensor board Digital 8-30 VDC PNP/NPN (Period 0902-)	9613-4434-01

How to contact Alfa Laval

Contact details for all countries are continually updated on our website.

Please visit www.alfalaval.com to access the information direct.

© Alfa Laval Corporate AB

This document and its contents is owned by Alfa Laval Corporate AB and protected by laws governing intellectual property and thereto related rights. It is the responsibility of the user of this document to comply with all applicable intellectual property laws. Without limiting any rights related to this document, no part of this document may be copied, reproduced or transmitted in any form or by any means (electronic, mechanical, photocopying, recording, or otherwise), or for any purpose, without the expressed permission of Alfa Laval Corporate AB. Alfa Laval Corporate AB will enforce its rights related to this document to the fullest extent of the law, including the seeking of criminal prosecution.