

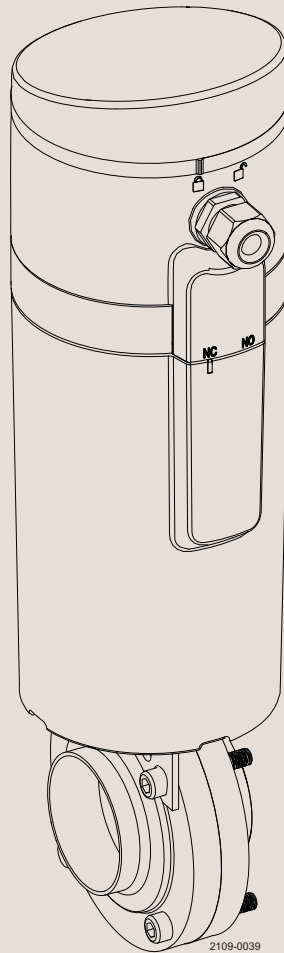

# Instruction Manual

## Unique Control for Butterfly Valves



ESE02126-EN 2012-02

Original manual



The information herein is correct at the time of issue but may be subject to change without prior notice

<b>1. EC Declaration of Conformity</b> .....	<b>4</b>
<b>2. Safety</b> .....	<b>5</b>
2.1. Important information .....	5
2.2. Warning signs .....	5
2.3. Safety precautions .....	5
2.4. Loss of air supply .....	6
<b>3. General information</b> .....	<b>7</b>
3.1. General information .....	7
<b>4. Installation</b> .....	<b>8</b>
4.1. Overview of installation instructions .....	8
4.2. Product dimensions .....	9
4.3. Mounting bracket kit on the actuator - step 1 .....	10
4.4. Mounting actuator on the valve head - step 2 .....	11
4.5. Connecting the air supply- step 3 .....	12
4.6. Connecting the communication cable- step 4 .....	13
4.7. Calibration- step 5 .....	16
4.8. Changing NC/NO functionality .....	17
4.9. Recycling information .....	19
<b>5. Troubleshooting</b> .....	<b>20</b>
5.1. Actuator position marking misaligned .....	20
<b>6. Technical data</b> .....	<b>22</b>
6.1. Technical data .....	22
<b>7. Parts list</b> .....	<b>23</b>
7.1. Parts list .....	23

# 1 EC Declaration of Conformity

The designating company

Alfa Laval

Company Name

Albuen 31, DK-6000 Kolding, Denmark

Address

+45 79 32 22 00

Phone No.

hereby declares that

Unique Control

Denomination

Actuator with integrated control  
for butterfly valve

Type

                      
Year

is in conformity with the following directives:

- Low Voltage Directive (LVD) 2006/95/EF
- EMC Directive 2004/108/EF
- ROHS Directive 2002/95/EEC
- Machinery Directive 2006/42/EC

Manager, Product Centre, Fluid Handling

Title

Bjarne Søndergaard

Name

Alfa Laval Kolding  
Company

Company



Signature

Designation



---

*Unsafe practices and other important information are emphasised in this manual.  
Warnings are emphasised by means of special signs. All warnings in the manual are summarised on this page.  
Pay special attention to the instructions below in order to avoid serious personal injury or damage to the top unit.*

---

### 2.1 Important information

---

**Always read the manual before using the Unique Control!**

#### WARNING

Indicates that special procedures must be followed to avoid serious personal injury.

#### CAUTION

Indicates that special procedures must be followed to avoid damage to the Unique Control.

#### NOTE

Indicates important information to simplify or clarify procedures.

---

### 2.2 Warning signs

---

General warning:



Danger of electrical voltage:



Caustic agents:



### 2.3 Safety precautions

---

#### Installation

**Always** read the technical data thoroughly (See chapter 6 Technical data).

**Always** release compressed air after use.

**Never** touch the coupling between the valve body and the actuator if compressed air is supplied to the actuator.

**Always** use a power supply that complies with IEC/EN60950-1 or IEC/EN61010-1 standard and limited-energy circuit requirements.



#### Operation

**Always** read the technical data thoroughly (See chapter 6 Technical data).

**Never** touch the valve or the pipelines when processing hot liquids or when sterilising.

**Never** touch the coupling between the valve body and the actuator if compressed air is supplied to the actuator.

**Always** handle lye and acid with great care.



#### Transportation

**Always** make sure that compressed air is released.

**Always** make sure that all connections are disconnected before attempting to remove the valve from the installation.

**Always** drain liquid out of valves before transportation.

**Always** used predesignated lifting points if defined.

**Always** ensure adequate fixing of the valve during transportation - if specially designed packaging material is available it must be used.

---

## 2 Safety

---

### 2.4 Loss of air supply

---



The Unique Control reacts differently to a loss of air supply compared to a regular spring-return actuator. e.g. the LKLA.

The Unique Control does not have a built-in spring to return the actuator to the de-energised position in cases of air supply failure. Instead, the Unique Control features a built-in check valve that ensures that the actuator remains in the current position if the air supply fails.

In the case of electrical power failure, the Unique Control responds in the same way as regular actuators installed with control heads from the ThinkTop series.

Please refer to the table below for an overview of the actuator responses in different error scenarios.

Error Scenario	Unique Control		Spring-return actuator (LKLA)		Actuator type Actuator status
	De-energised	Energised	De-energised	Energised	
Air pressure lost	No change	No change	No change	Actuator changes to De-energised position	Actuator response
Electrical power lost	No change	Actuator changes to De-energised position	No change	Actuator changes to De-energised position	

---

### 3.1 General information

---

#### Concept

Unique Control for butterfly valves is an actuator with integrated automation for LKB butterfly valves. Unique Control is a hygienic, reliable solution with a focus on simplicity.

The Unique Control complements our existing range of actuators and control units and it provides the opportunity to upgrade an existing installation.

Unique Control is compatible with all major PLC systems. It is for use in food, dairy and brewery installations and in biopharmaceutical applications.

#### Working principle

The Unique Control uses an air spring allowing operation at a significantly lower air pressure compared to a conventional mechanical spring. The integrated intelligent automation will self-configure and calibrate with a single press of a button. The actuator is designed for easy onsite configuration as either normally open (NO) or normally closed (NC). The maintenance-free but serviceable actuator design is tested to perform over one million strokes.

The Unique Control has a 360 deg. indication light for visual status.

It also provides the opportunity to monitor the status of the operating air pressure, identifying air leakage or failing air pressure.

---

## 4 Installation

---

### 4.1 Overview of installation instructions

---

#### Step 1

Mount bracket kit on actuator.

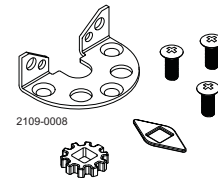

#### Step 2

Mount actuator on valve head.

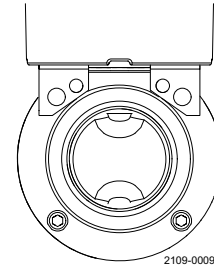

#### Step 3

Connect air supply.

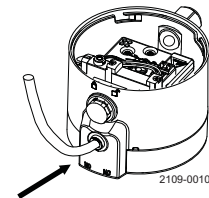

#### Step 4

Connect communication cable.

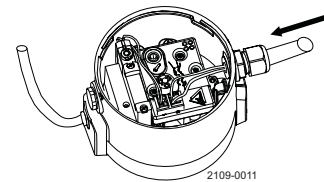

#### Step 5

Calibrate.

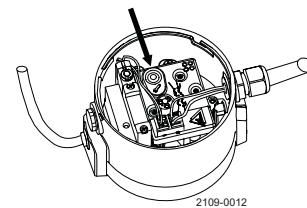



4.2 Product dimensions

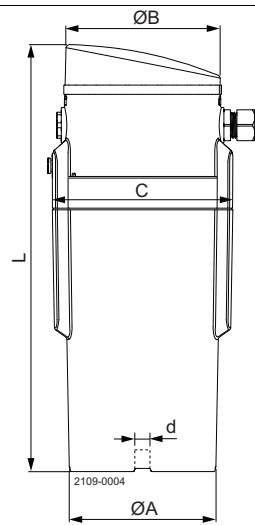

Size	25-63.5 mm DN25-50	76.1 mm DN65-80	101.6 mm DN100
$\varnothing A$	90	90	90
$\varnothing B$	97	97	97
C	111	111	111
L	263	263	263
d	8	10	12
Weight (kg)	1.6	1.6	1.6

## 4 Installation

---

### 4.3 Mounting bracket kit on the actuator - step 1

---

#### Step 1

Mount the coupler (A) in the slot on the bottom side of the actuator.

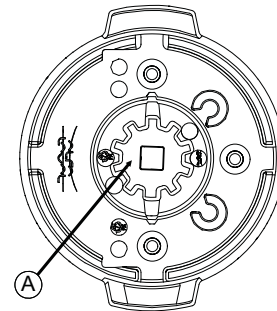

#### Step 2



Be aware that the actuator position marking on the bottom of the actuator is aligned as shown on drawing (B).  
In cases where the actuator position marking is not aligned, please refer to the troubleshooting section for an instruction on how to re-align it.

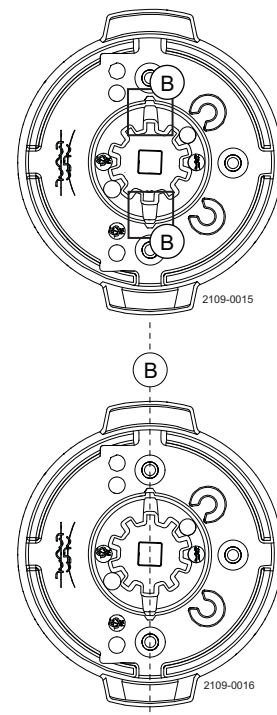

#### Step 3

Mount the bracket using the 3 enclosed screws (D).  
The tightening torque is 10 Nm.



#### NOTE!

The enclosed screws are applied with a thread-locking adhesive.  
In the case of dismantling and later reassembly, the screws must be secured with a thread-locking adhesive.

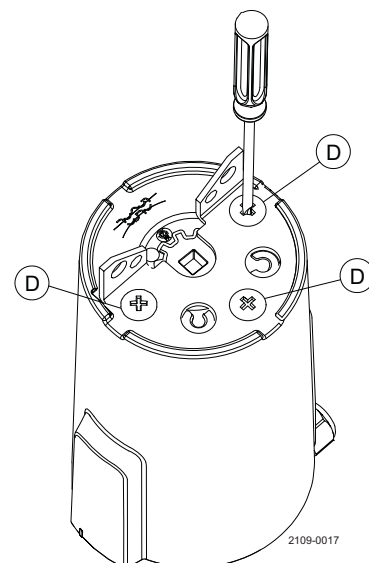

### 4.4 Mounting actuator on the valve head - step 2

This instruction applies for both NC and NO actuators.

#### Step 1

Mount the arrow for mechanical open/closed indication of the valve (E).



The valve must be closed when the actuator is mounted.

#### NOTE!

NO/NC functionality of the actuator is changed in the control head.

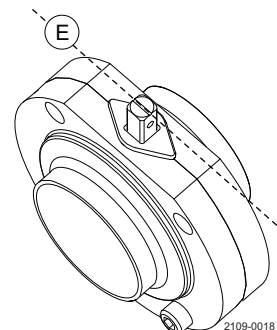

#### Step 2

Mount the actuator on the valve head using the enclosed bolts (F).

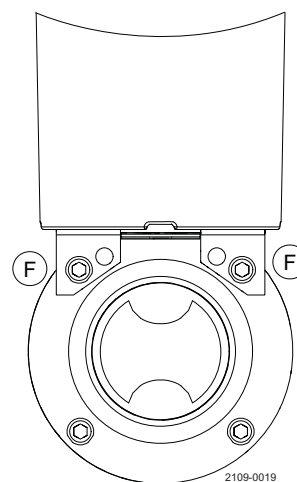

## 4 Installation

---

### 4.5 Connecting the air supply- step 3

---

#### Step 1

Connect the air supply hose to the  $\varnothing 6$  mm air fitting ( I ).

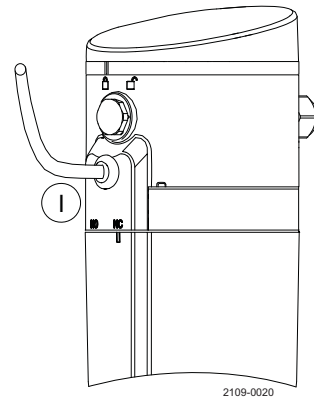

#### Step 2

#### NOTE!

For a  $\frac{1}{4}$ " air supply hose.

Connect the air supply hose via the  $\varnothing 6 / \frac{1}{4}$ " angle adaptor.  
(Article number:  $\varnothing 6 / \frac{1}{4}$ " angle adaptor: 9611-99-5311)

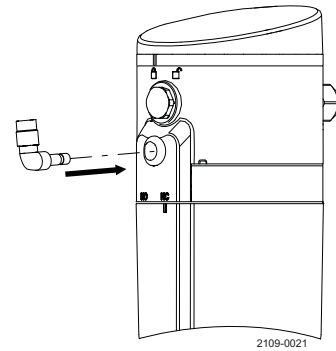

---

#### 4.6 Connecting the communication cable- step 4

---

##### Step 1

Remove the prism/top cover by turning the prism/top cover counter-clockwise.

When the mark on the prism (J) is aligned with the open padlock symbol (K), the prism/top cover can be lifted off.

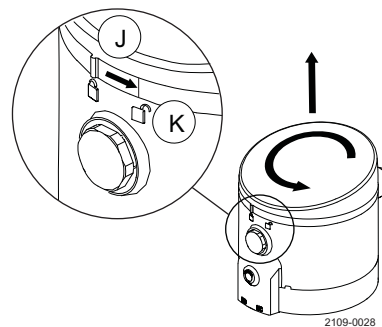

##### Step 2

Install the cable in the cable gland (M).

##### NOTE!

Cable connection:

Main cable gland: PG9 (ø4-ø8 mm)

Max. wire diameter: 1.0 mm<sup>2</sup> (AWG 18).



If the cable gland comes loose from the control head during installation, it must be secured with a tightening torque of 4 Nm.

---

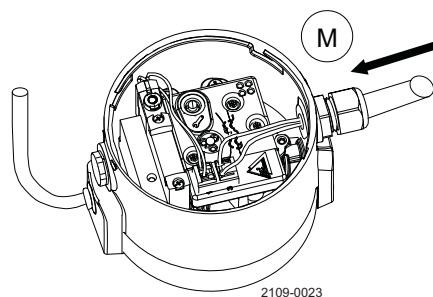

## 4 Installation

### Digital version – PNP

<b>Supply voltage</b>	
Supply voltage	24 VDC ± 10%
<b>Max. power consumption of the sensor unit</b>	
Solenoid valve not active	50mA
Solenoid valve active	65mA
<b>Output signals from the sensor unit to the connected digital interface (PLC).</b>	
Nominal voltage	Same as connected to the Unique Control
Load current	50 mA typical, 100 mA max
Voltage drop	Typical 3V @ 50 mA

### Electrical connection for digital version (PNP)

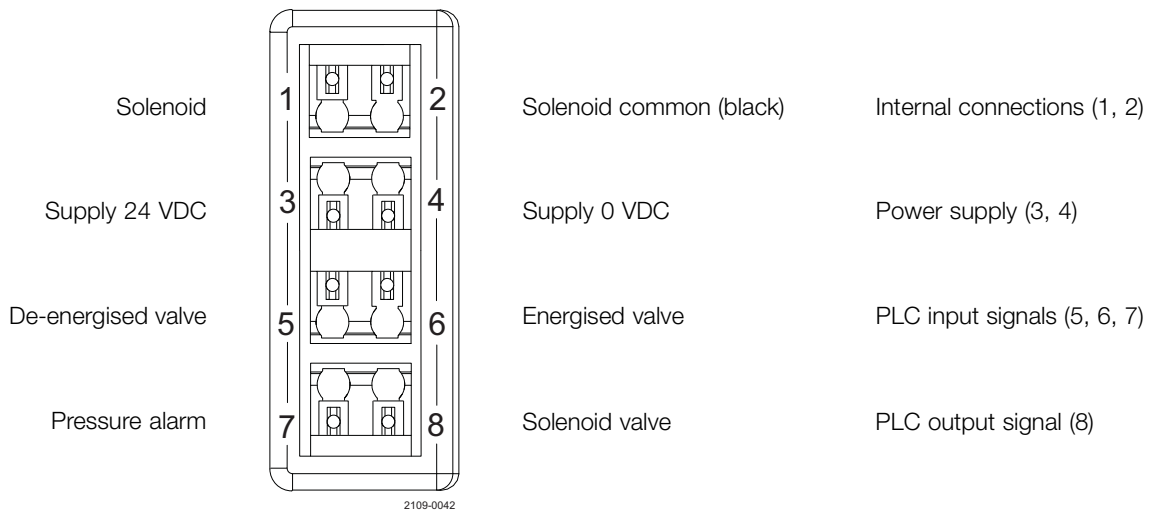

## AS-Interface version

The power supply to the complete unit is taken from the AS-Interface loop. The unit is reverse polarity protected.

Supply voltage	
Supply voltage	29.5 - 31.6 VDC
AS-Interface profile code	
AS-I v2.11 (31 nodes)	7.F.F.F
AS-I v3.0 (62 nodes)	7.A.7.7
Max. power consumption of sensor unit	
Solenoid valve not active	50mA
Solenoid valve active	65mA

## AS-Interface bits assignment

DI0 ..... De-energised valve (feedback #1)  
 DI1 ..... Energised valve (feedback #2)  
 DI2 ..... NC  
 DI3 ..... Pressure alarm (feedback #4)

DO0 ..... NC  
 DO1 ..... Solenoid valve (output #2)  
 DO2 ..... NC  
 DO3 ..... NC

## Electrical connection for AS-i versions

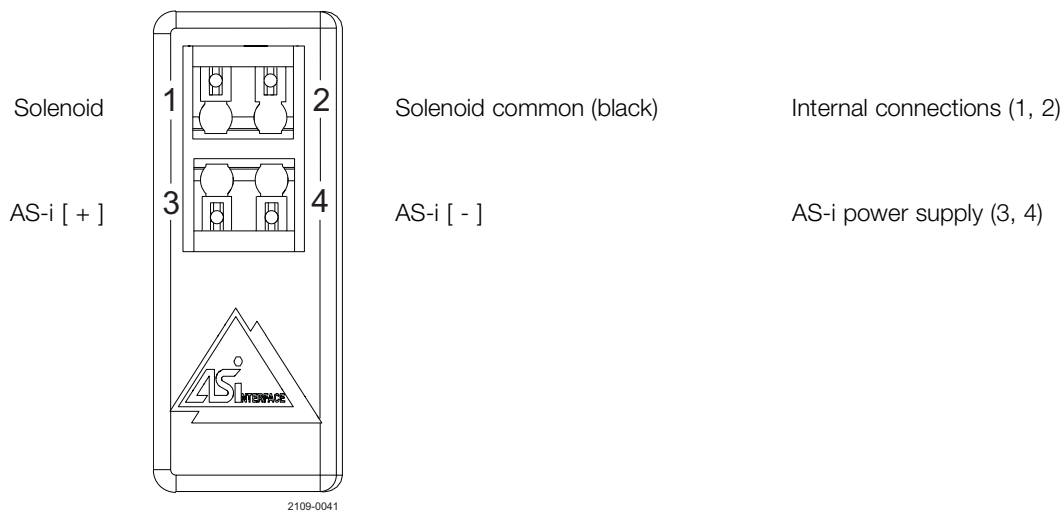

## 4 Installation

---

### 4.7 Calibration- step 5

---

#### Step 1

##### Prerequisite

The Unique Control must be fully installed:

- Mechanically
- Pneumatically
- Electrically

The unit will flash green, when ready to calibrate the first time.

##### Calibrate

Push the blue button (N) on the sensor unit until you see a yellow flash.

The Unique Control will automatically calibrate.

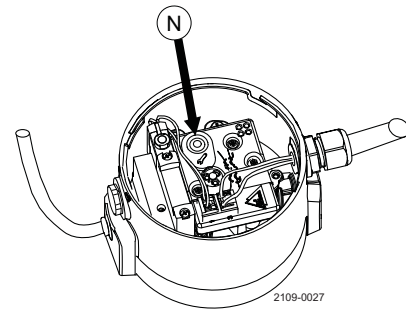

The unit is ready to use when the green light comes back on.

---

#### Step 2

Put the prism/top cover back on by pushing it down when the mark on the prism (J) and the open padlock (K) are aligned. Then turn it clockwise towards the closed padlock (L) to secure the top.

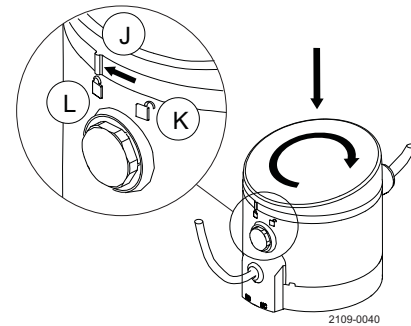

#### Operating LED feedback

Actuator status	LED feedback
De-energised	Green
Energised	Yellow
Pressure alarm (De-energised)	Red/green flashing
Pressure alarm (Energised)	Red/yellow flashing

---



## 4.8 Changing NC/NO functionality

The following instruction shows how to change the Unique Control from “Normally Closed” to “Normally Open” functionality.

### Step 1



Disconnect the air supply.

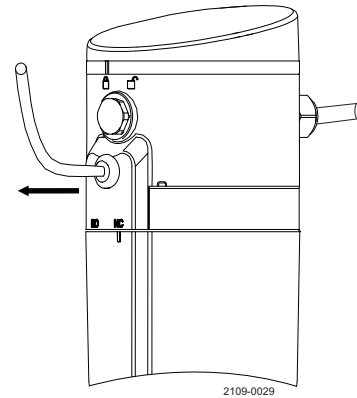

### Step 2

Remove the prism/top cover by turning the prism/top cover counter-clockwise.

When the mark on the prism (J) is aligned with the open padlock symbol (K) the prism/top cover can be lifted off.

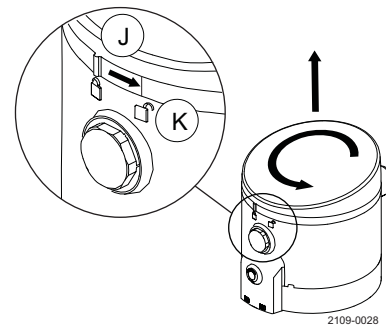

### Step 3

Loosen the 4 screws (D) inside the control head.

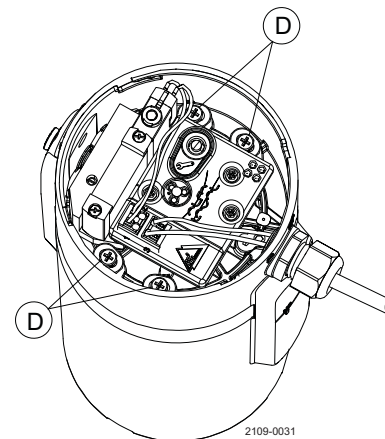

## 4 Installation

---

### Step 4

Lift off the control head and be aware that the 4 O-rings (E) remain in the grooves.

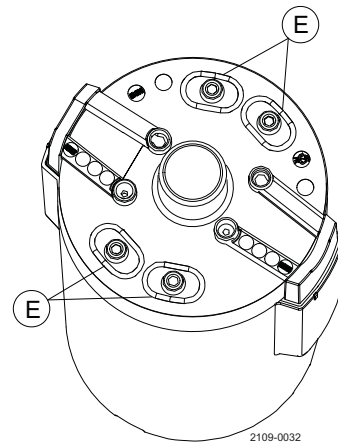

### Step 5

Turn the control head 180 degrees and check that the marking (F) is aligned with the NO symbol.

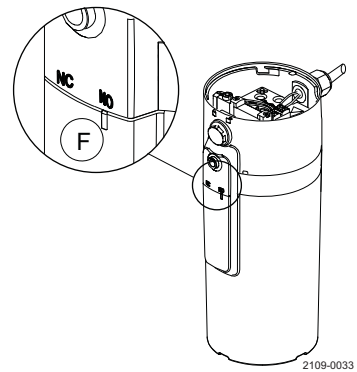

### Step 6

Re-attach the control head to the actuator by tightening the 4 screws (G) with a tightening torque of 2Nm.

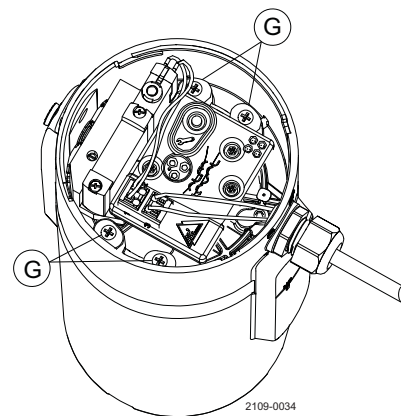

### Step 7

Reconnect the air supply and re-power the Unique Control to complete the change.

See Step 3 and Step 5 in chapter 4 Installation for details.

### Step 3

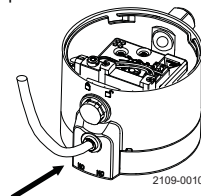

### Step 5

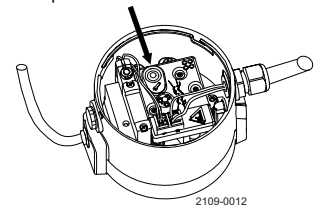

### 4.9 Recycling information

---

- **Unpacking**

- Packing material consists of wood, plastics, cardboard boxes and in some cases metal straps
- Wood and cardboard boxes can be re-used, recycled or used for energy recovery
- Plastics should be recycled or burnt at a licensed waste incineration plant
- Metal straps should be sent for material recycling

- **Maintenance**

- During maintenance, oil and wearing parts in the machine are replaced
- All metal parts should be sent for material recycling
- Worn out or defective electronic parts should be sent to a licensed handler for material recycling
- Oil and all non-metal wearing parts must be taken care of in accordance with local regulations

- **Scrapping**

- At end of life, the equipment must be recycled according to the relevant, local regulations. Besides the equipment itself, any hazardous residues from the process liquid must be taken into consideration and dealt with in a proper manner. When in doubt, or in the absence of local regulations, please contact your local Alfa Laval sales company
-

## 5 Troubleshooting

---

### 5.1 Actuator position marking misaligned

---

The following instruction will re-align the actuator position marking on the bottom of the actuator in order to continue the general installation.

The instruction depends on the actuator configuration.

---

#### NC actuator

##### Step 1

The actuator configuration can be verified on the marking on the outside of the control head (A).

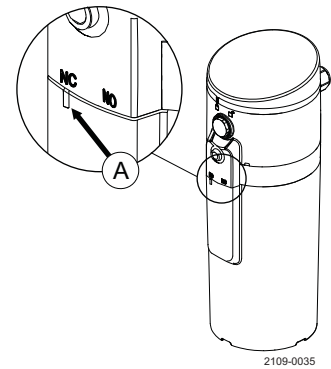

##### Step 2

1. Connect air supply to the actuator.
2. Disconnect air supply to the actuator



Beware of the movement of the coupler.

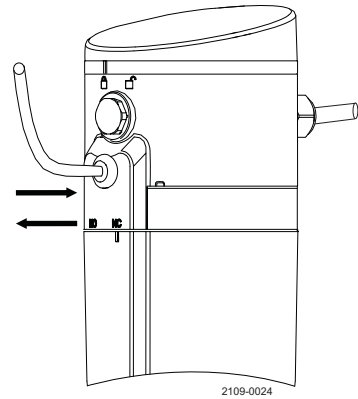

##### Step 3

##### Verification

Check that the actuator position marking is aligned.

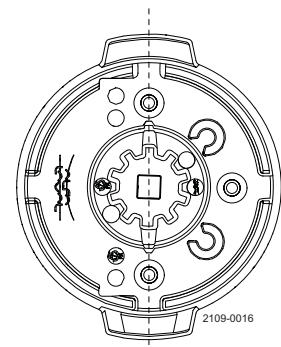

### NO actuator

#### Step 1

The actuator configuration can be verified on the marking on the outside of the control head (A).

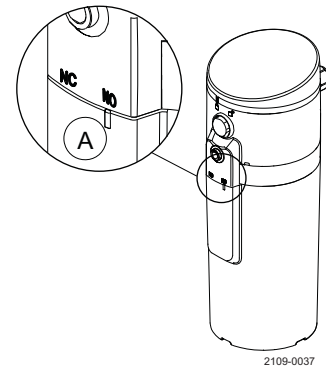

#### Step 2

1. Connect air supply to the actuator.



Beware of the movement of the coupler.

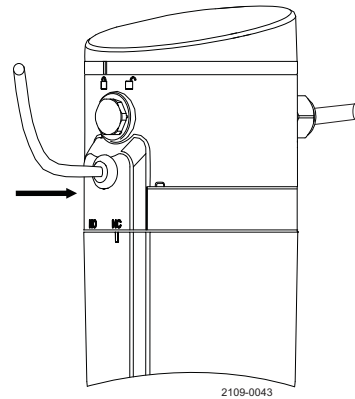

#### Step 3

1. Activate the manual override (B) on the solenoid valve.  
2. Disconnect air supply to the actuator.



Beware of the movement of the coupler.

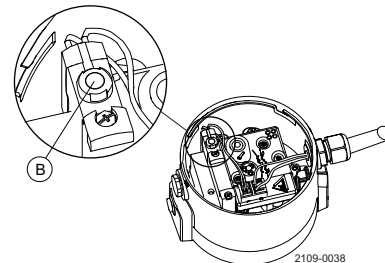

#### Step 4

##### Verification

Check that the actuator position marking is aligned.

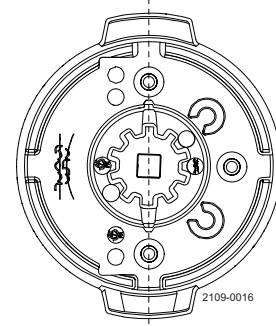

## 6 Technical data

### 6.1 Technical data

<b>Actuator</b>	
Max. air pressure	800 kPa (8 bar)
Min. air pressure	300 kPa (3 bar)
Working temperature	-5°C to +60°C
Protection class	IP66 and IP67
Air consumption (on each stroke)	0.8 x p (volume x pressure)
Push-in fittings	6 mm
<b>Communication</b>	
<b>Option 1</b>	
Interface	Digital
Supply voltage	24 VDC ± 10%
<b>Option 2</b>	
Interface	AS-Interface v2.1, 31 node
Supply voltage	29.5V - 31.6 VDC
Slave profile	7.F.F.F
Default slave address	0
<b>Option 3</b>	
Interface	AS-Interface v3.0, 62 node
Supply voltage	29.5V - 31.6 VDC
Slave profile	7.A.7.7
Default slave address	0
<b>Sensor board</b>	
Power supply	24 VDC, 1 W
Feedback signal #1	De-energised valve
Feedback signal #2	Energised valve
Feedback signal #3	Pressure alarm
Valve tolerance band	Auto setup
<b>Solenoid valve</b>	
Supply voltage	24 VDC ± 10%, 1 W
Air supply	300-800 kPa (3-8 bar)
Type of solenoid	4/2-way
Number of solenoids	1
Manual hold override	Yes
<b>Physical data</b>	
<b>Materials</b>	
Actuator body	Black nylon PA 12 (reinforced)
Steel parts	1.4301 (304) and 1.4404 (316)
Seals	NBR
<b>Compatible valves</b>	
LKB ISO	25, 38, 51, 63.5, 76.1 and 101.6 mm
LKB-2	DN 25, 32, 40, 50, 65, 80 and 100
<b>Cable connection</b>	
Main cable gland	PG9 (ø4 - ø8 mm)
Max. wire diameter	1.0 mm <sup>2</sup> (AWG 18)

7.1 Parts list

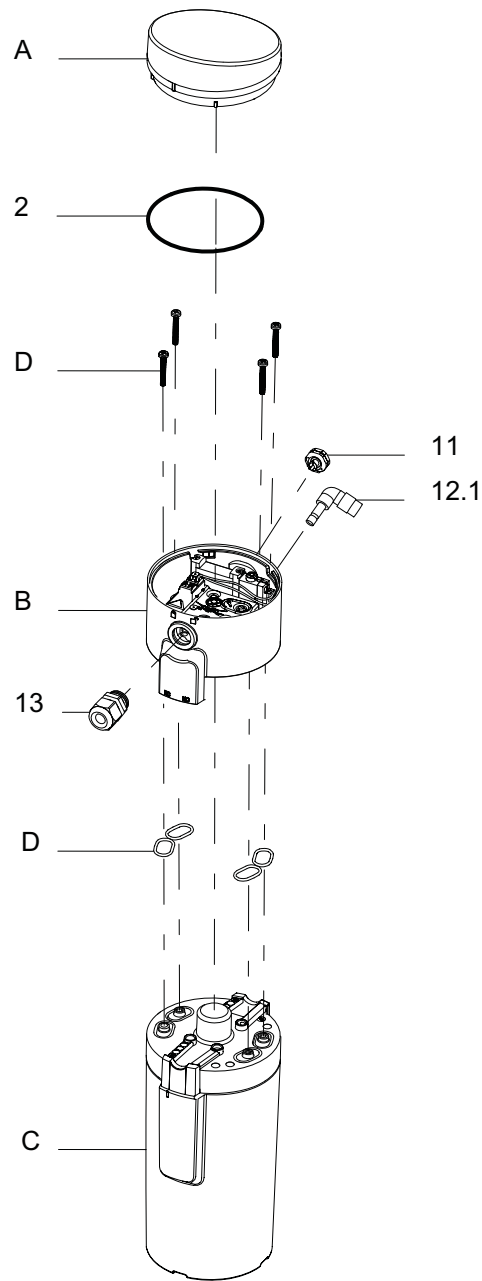

2109-0007

## 7 Parts list

---

### Parts list

---

Pos.	Qty	Denomination
A		Top incl. prism and o-rings
B		Base, cpl.
C		Cylinder, cpl.
D		Screws and o-rings
2	1	O-ring
11	1	Gore Vent
12.1	1	Air fitting
13	1	Cable gland PG9

---



---

**How to contact Alfa Laval**

Contact details for all countries are continually updated on our website.

Please visit [www.alfalaval.com](http://www.alfalaval.com) to access the information directly.

© Alfa Laval Corporate AB

This document and its contents is owned by Alfa Laval Corporate AB and protected by laws governing intellectual property and thereto related rights. It is the responsibility of the user of this document to comply with all applicable intellectual property laws. Without limiting any rights related to this document, no part of this document may be copied, reproduced or transmitted in any form or by any means (electronic, mechanical, photocopying, recording, or otherwise), or for any purpose, without the expressed permission of Alfa Laval Corporate AB. Alfa Laval Corporate AB will enforce its rights related to this document to the fullest extent of the law, including the seeking of criminal prosecution.