



Leave Surveillance to the Top

ThinkTop® DeviceNet™ 11-25 VDC

Concept

The ThinkTop® is designed to ensure optimum valve control in conjunction with Alfa Laval sanitary butterfly, single-seat and Mixproof valves and it is compatible with all major PLC systems (Programmable Logic Controller with PNP/NPN interface). It is for use in food, dairy and brewery installations and in biopharmaceutical applications.

Working principle

The ThinkTop® is a control head including indication units and solenoid valves to control all kinds of processing valves. It is used to control and supervise pneumatic valves and it is mounted on the top of the valve. It receives signals from a PLC to control the valve and it sends feedback signals to the PLC to indicate when the valve is in a certain position. To adapt the sensor board to the specific valve and to the application, the user sets up the ThinkTop either by the local keys or by using the key pad (which is ordered separately). When using the key pad it is not necessary to dismantle the top unit.



TECHNICAL DATA

Communication

Interface	DeviceNet
Supply voltage	11 - 25 VDC
Class 4 messaging	2 byte Polling
Baud rates	125K, 250K, 500K
Default slave address	63

Sensor board

Power supply	24 VDC, 1 W
Feedback signal #1	Closed valve
Feedback signal #2	Open valve
Feedback signal #3	Seat-lift 1 or 1 External signal
Feedback signal #4	Seat-lift 2 or 1 External signal
Feedback signal #5	Status
Valve tolerance band	1-5
Default tolerance band	± 5 mm
Sensor accuracy	± 0.1 mm
Stroke length	0.1 - 80 mm

Solenoid valve

Supply voltage	24 VDC ± 10%, 1 W
Air supply	300-900 kPa (3-9 bar)
Type of solenoids	3/2-ways or 5/2-ways
Numbers of solenoids	0-3
Manual hold override	Yes
Throttle function air inlet/outlet	0-100 %
Push-in fittings	ø6 mm or 1/4"

PHYSICAL DATA

Materials

Plastic parts	Blue Nylon PA 12 Reinforced
Steel parts	1.4301 (304) and 1.4404 (316)
Seals	Nitrile (NBR) rubber

Environment

Working temperature	-20°C to +85°C
Protection class	IP66 and IP67

Cable connection

Main cable gland	PG11 (ø4 - ø10 mm)
Cable gland for external sensor	PG7 (ø3 - ø6.5 mm)
Max wire diameter	0.75 mm ² (AWG 20)

DeviceNet features			
Generic		Master/scanner	
		I/O Slave messaging supported by ThinkTop® DeviceNet	
Explicit peer to peer messaging	No	• Bit strobe No	No
I/O peer to peer messaging	No	• Polling	Yes
Configuration consistency value	No	• Cyclic	No
Faulted node recovery	No	• Change of state (COS)	No
Configuration method	EDS fil, Top46-7j	ThinkTop before 2012	
	EDS fil, T-Top RTA	ThinkTop after 2012	

Typical Power Consumption ThinkTop

Test conditions = One ThinkTop connected with 1 feedback active (on) and			
No solenoid valve on	Supply voltage 24 VDC		34 mA
1 solenoid valve active	Supply voltage 24 VDC		58 mA
2 solenoid valves active	Supply voltage 24 VDC		82 mA
3 solenoid valves active	Supply voltage 24 VDC		106 mA

Electrical connection

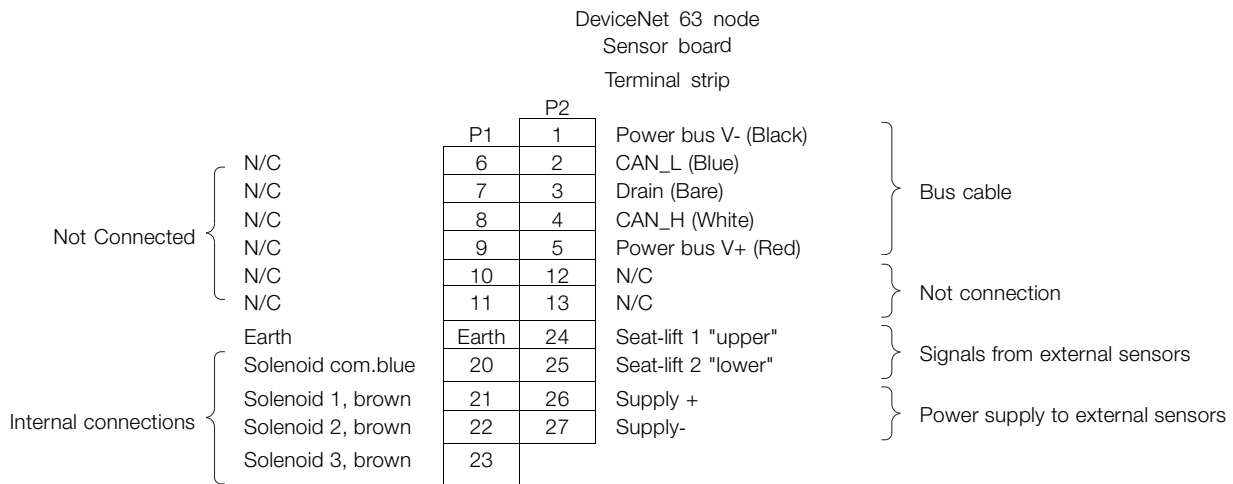

DeviceNet bits assignment

For DeviceNet the following bit assignment can be used

Valve value	
DI0	Feedback #1 Closed valve
DI1	Feedback #2 Open valve
DI2	Feedback #3 Seatlift 1
DI3	Feedback #4 Seatlift 2
DI4	Feedback #5 Status
DI5	Feedback #6 Not Connected
DI6	Feedback #7 Not Connected
DI7	Feedback #8 Not Connected
Valve command	
DO0	Out #1 Not Connected
DO1	Out #2 Solenoid valve 1
DO2	Out #3 Solenoid valve 2
DO3	Out #4 Solenoid valve 3
DO4	Out #5 Not Connected
DO5	Out #6 Not Connected
DO6	Out #7 Not Connected
DO7	Out #8 Not Connected

Dimensions

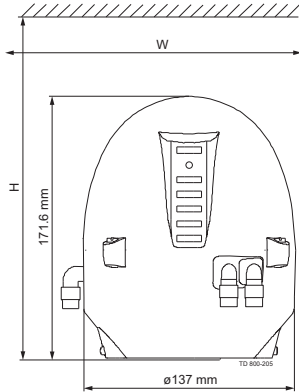

Note! This is the basic design.		
Recommended clearance around the ThinkTop		
Valve Type	W	H
Unique SSV NC	225	250
SMP-SC/-BC/-TO	225	250
Unique Mixproof	225	250
MH	225	250
SBV	225	250
Unique SSV NO	225	320
LKLA-T	225	300

Basic design

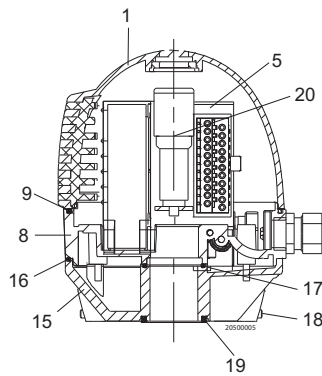
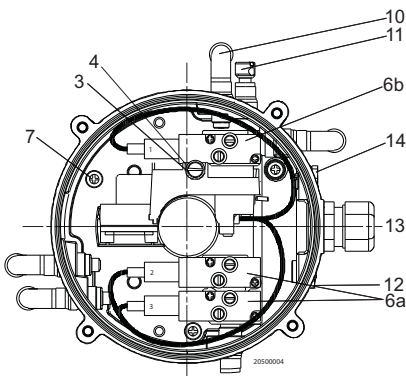

1. Shell
2. N/A
3. Screw
4. Washer
5. Sensor board
6. Solenoid valve*
7. PT screw
8. Base
9. Special X-ring, grey
10. Air fittings
11. Blow-off valve
12. Thread plug, PG7
13. Cable gland, PG11
14. Gore Vent. membrane
15. Adapter
16. Special X-ring, black
17. O-ring
18. Allen screw
19. Special X-ring
20. Indication pin

* 6a: Solenoid valve (3/2)

* 6b: Solenoid valve (3/2 or 5/2).

Options

- Gore Vent. w/adapter (Fig. 1 Basic Design pos. 14) for ThinkTop before November 2006; 9613-4315-01

Accessories

- IR keypad
- External PNP sensors
- Main cable gland PG11
- Cable gland PG7 for external sensor
- External sensor bracket for Unique Mixproof

Ordering

Please state the following when ordering:

- ThinkTop DeviceNet 63 node .
- Number of solenoid valves (0-3).
- Type of solenoid valves (3/2 or 5/2).
- Push-in fittings \varnothing 6 mm or 1/4"
- Please state if for series 700 valves.
- Special indication pin; 9613-1581-01 For Unique SSV-LS valves
- Special indication pin; 9612-6370-01 For SRC-LS Stop valve size 63.5-101.6 mm/DN 65 - 100
- Special indication pin; 9613-1581-01 For Unique SSV High Pressure valve size 76.1-101.6 mm/DN 80-100

Note!

For further information: See also ESE000355

The ThinkTop has Patented Sensor System, Registered Design and Registered Trademark owned by Alfa Laval



DeviceNet[®]
CONFORMANCE TESTED

Alfa Laval reserves the right to change specifications without prior notification. ALFA LAVAL is a trademark registered and owned by Alfa Laval Corporate AB.

ESE00299EN 1201

© Alfa Laval

How to contact Alfa Laval

Contact details for all countries are continually updated on our website. Please visit www.alfalaval.com to access the information direct.